

TelePost LP-500 Digital Station Monitor

Reviewed by Martin Ewing, AA6E
aa6e@arrl.net

In the United States, the Federal Communications Commission (FCC) requires us to operate “in accordance with good engineering and good amateur practice.” Are we using excessive power for the conditions? Are our signals distorted or interfering with other hams?

The first station accessory that many hams will acquire is a power and standing-wave ratio (SWR) meter. This will assure you that your radio puts out the power it should and that your antenna and feed line accept power without reflecting too much back to you — your SWR is less than (say) 2:1, with 1:1 being ideal.

For years, even in the AM days, some hams purchased or built specialized test equipment to monitor their modulation quality to avoid over-modulation and splatter. It is important now for SSB voice and some digital modes, where transmitter and amplifier linearity is critical. (If your amplifier’s output power is not exactly proportional to the input signal, it is nonlinear and your signal may cause interference to other hams.) We buy “linear” amps, but they can often be misadjusted or overdriven into a nonlinear condition.

Clean signals are more important than ever, but modulation monitors are still not very common. Our radios have improved so that if you read the manual and adjust them with reasonable care, you will transmit a good signal. They generally monitor power and SWR for you. On the other hand, our stations and our operating modes have gotten quite a bit more complicated. Some digital modes, such as PSK31, require good transmit linearity in order to be decoded well.

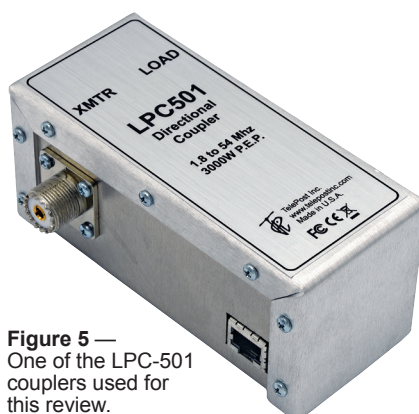

Figure 5 — One of the LPC-501 couplers used for this review.

The TelePost LP-500 is the latest in a line of signal-monitoring products that began with the LP-100 Digital Vector RF Wattmeter.¹ As a longtime user of the LP-100, I was eager to see how the LP-500 would stack up.

The LP-500 is basically a specialized digital oscilloscope and tone generator integrated with a high-quality SWR and power meter. It sports a

¹J. Hallas, W1ZR, “Three Antenna System Measurement Devices,” Product Review, *QST*, Aug. 2007, pp. 67 – 73.

Bottom Line

This flexible monitor helps you transmit a clean and legal signal.

5-inch, 800 × 480 pixel color touch-screen. (The LP-700 product is identical but with a 7-inch screen.) The LP-500 does not support the complex impedance measurements that are possible with the LP-100/100A products.

The LP-500 accepts signals from up to four remote directional couplers via CAT5 or CAT6 ethernet-type cabling. Six-foot shielded cables are supplied, but unshielded cables or longer cable runs “of any practical length” are supposed to work.

Several coupler models are available. Covering HF and 6-meter bands, you can choose a 3 kW or 5 kW model. If you *really* need more power capability, there is an HF-only 10 kW model. VHF/UHF couplers are coming, according to TelePost. In these tests, we used two of the LPC501 HF/6-meter 3 kW couplers (see Figure 5).

Connections

Figure 6 shows the LP-500 rear panel. CH1 to CH4 are the coupler connections. Couplers can be used to measure power and SWR on up to four separate transmitters or amplifiers. They can also be used in pairs to monitor operation of a power amplifier. A possible setup is shown in Figure 7. Here, couplers 1 and 2 are

used to monitor a transceiver and to check linearity of its attached linear amplifier. A third coupler monitors a “barefoot” transceiver using a separate antenna. Many other configurations from one to four couplers are possible to support up to four separate transmitters or to check linearity of two linear amplifiers. (Only one coupler or coupler pair can be monitored at a time.)

You can feed the output of the LP-500’s tone generator (**TEST TONES**) into an available audio input of a transceiver. You could use the main microphone input, but many rigs offer separate microphone or line inputs that may be more convenient. The tone generator can be set to supply a variety of waveforms: a two-tone SSB test (1.5 and 1.7 kHz), a continuous 400 Hz or 1 kHz tone, or a “white” or “pink” noise signal.

An optional PTT (push-to-talk) signal from the transceiver can be routed through the LP-500’s **PTT RELAY** jacks on its way to the linear. This allows the LP-500 “alarm” feature to block PTT and protect the amplifier if excess SWR is seen. This connection is only needed for amps that do not have their own internal protective circuitry.

What We Can Measure

There are three major screen displays: power/SWR, waveform, and spectrum. The basic power/SWR screen is the wattmeter and SWR display. Power and SWR are both shown in large numbers. Additionally, you get bar graphs of peak and average power and SWR that are especially helpful when you’re tuning up your amp or antenna tuner (see the lead photo).

The waveform mode allows you to see modulation in the time domain, like a conventional oscilloscope, but there are numerous useful variations in addition to the simple modulation display. For example, you can monitor

Table 2
TelePost LP-500, S/N 0325

Firmware tested: v. 2.51.08b; VM software: v. 1.076.
Specified frequency range: 1.8 to 54 MHz with appropriate coupler.
Specified power range: 0.1 to 3 kW PEP / 1,500 W average (with LPC-501 coupler).
Absolute power accuracy specification: Better than 3% at 14 MHz, NIST traceable; ±0.1 dB variation from 1.8 to 50 MHz.
Power requirements: 13.8 V dc at 500 mA. Operation checked at 8 – 15 V.
Audio output level at **TEST TONES** jack: 0.1 V_{RMS} typical with single tone.
Size (height, width, depth): 4.7 × 9.2 × 7.0 inches, including protrusions.
Weight: Meter, 2.8 lbs; coupler, 0.6 lbs.

Laboratory Measurements

Forward Power	----- LP-500 Power Display -----				
	1.8 MHz	3.5 MHz	14 MHz	28 MHz	50 MHz
10 W	10.1	10.1	10.1	10.3	9.9
100 W	100	100	100	101	99
500 W	516	518	532	534	545
1,000 W	1,040	1,042	1,066	1,075	—*

Freq. (MHz)	Resistive Load (Ω)	Load SWR	LP-500 Reading	Freq. (MHz)	Resistive Load (Ω)	Load SWR	LP-500 Reading
1.8	13.0	3.84	3.93	14	13	3.84	3.68
	25.6	1.95	1.96		25.6	1.95	1.87
	51	1.02	1.02		51	1.02	1.02
	101	2.02	1.90		101	2.02	1.89
	201.1	4.02	3.76		201.1	4.02	2.72
3.5	13	3.84	3.88	28	13	3.84	3.35
	25.6	1.95	1.95		25.6	1.95	1.78
	51	1.02	1.01		51	1.02	1.02
	101	2.02	1.90		101	2.02	1.86
	201.1	4.02	3.76		201.1	4.02	3.75

*Note: 1,000 W signal at 50 MHz not available with Laboratory amplifier.

leading and trailing edges of your CW keying. Figure 8 shows a keying waveform for my FlexRadio 6500 transceiver. Note that the two halves of the display show the rising and trailing edge of the keyed RF dit or dah. The long constant signal between rise and fall is neatly suppressed. This lets you easily measure the rise and fall times that determine if you’re transmitting clean, click-free CW.

You can view the traditional trapezoid display (discussed below) to check linearity of amplifier output versus input, using two couplers. There is a mode for AM that shows the modulation and the positive- and negative-going peak power. Finally, there are combination modes that show modu-



Figure 6 — The LP-500 rear panel with connections for power, PTT relay, test tone output, USB connection to a computer, and four couplers. (Lab tests were performed with LP-500 serial number 0325; see the Lab Notes sidebar.)

lation alongside power/SWR or a trapezoid.

In spectrum mode, you can view the audio output spectrum of the coupler output. This can be used for linearity checks or to help equalize your microphone audio.

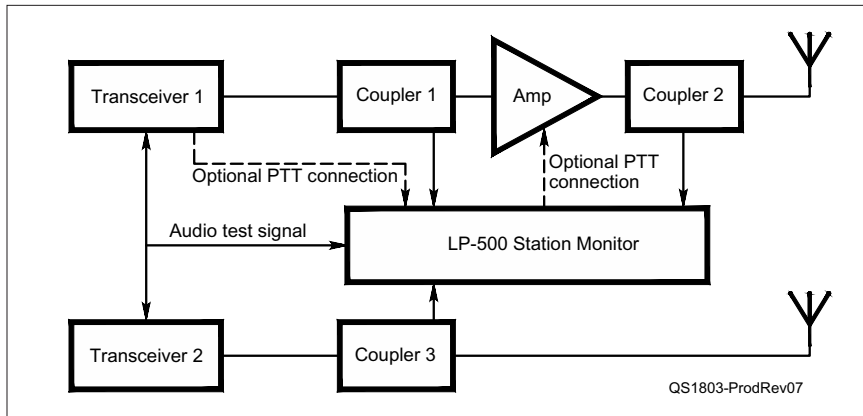

Figure 7 — Dual-transmitter, single-amplifier setup.

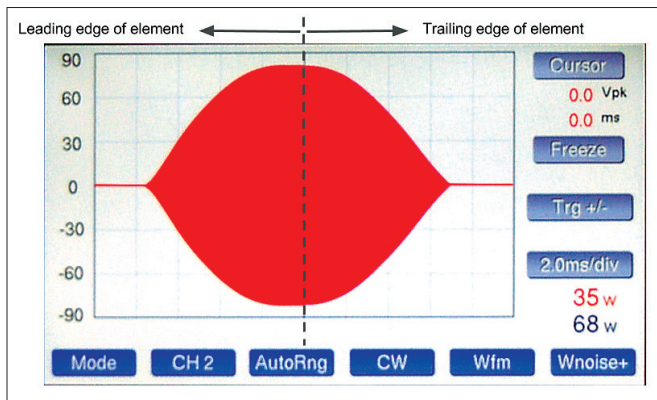

Figure 8 — Display of leading and trailing edge of code element.

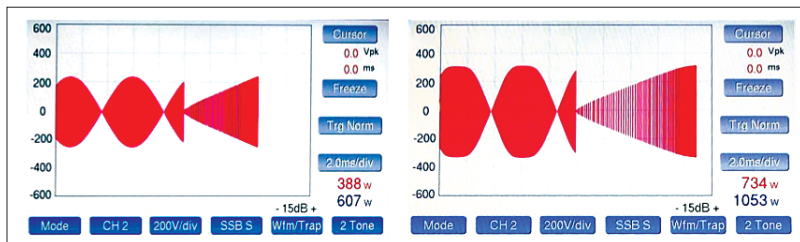

Figure 9 — Combined two-tone waveform and trapezoid. The display on the left shows good linearity and the display on the right shows poor linearity (overdriven amplifier).

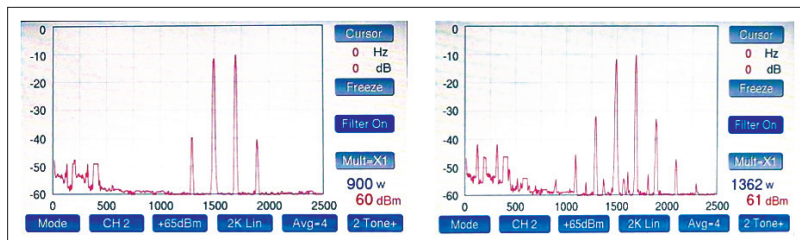

Figure 10 — IMD display with two-tone input. The display at the left shows moderate IMD, while the display at the right shows high IMD (overdriven amplifier).

Distortion and Linearity

The power, SWR, and waveform displays are very useful, but the most interesting features of the LP-500, to my mind, are the tests to check the linearity of your amplifier using the built-in, two-tone generator. We will go through two of these in a bit more detail using a Heath SB-220 amplifier driven by a FLEX-6500 transceiver.

The LP-500's combined waveform and trapezoid display (see Figure 9) lets you view your amplifier's performance in two related ways when you set up couplers on the input and output side of the amp. At the left side of the screen is the modulation waveform, where you can check for flat-topping when the normal sine wave may saturate on modulation peaks and depart from the desired sine wave appearance. At the right side, you can also check the trapezoid display. It should appear as a triangle with straight sides. Figure 9A shows good waveforms with a well-adjusted amplifier. When the amplifier drive level gets too high, you will see flat-topping and a curved trapezoid as in Figure 9B. The waveform/trapezoid method works with any audio waveform (not just the two tone), so you can monitor operation while you're transmitting SSB voice, for example.

A different test works in the frequency domain (i.e., the audio spectrum from a single coupler). This lets you estimate the intermodulation distortion (IMD) at the amplifier output, if you use the two-tone test signal. Technically, you can't really do this with only the test signal and an audio detector, but TelePost has implemented a clever scheme that injects a 200 Hz tone in addition to the two-tone signal. Your transmitter effectively transmits an AM-modulated signal where the low tone acts as a carrier. With some wizardry in the LP-500, you see a spectrum with just the two tones if IMD is low. If the amp is nonlinear, you will see other spectral components coming up due to IMD, very similar to the result we get from a lab

spectrum analyzer. Figure 10 shows typical displays you might encounter.

The spectrum scheme gives a useful relative indication of IMD performance, but the results are tricky to calibrate if you want an accurate number. It does have the advantage that you only need one costly coupler, but it only works with the two-tone test signal. The waveform/trapezoid method can work with voice modulation (and it shows you how your speech processing is working), but it needs two couplers the way TelePost has done it.

I note that the traditional way of generating the trapezoid on an oscilloscope uses the audio input power (voltage squared) to drive the X axis and the RF output power to drive the Y axis of the display, but the LP-500 does not support this. The two-coupler method (with the first coupler driving the X axis and the second driving the Y) does have the advantage of separating the performance of the amplifier from that of the transceiver/exciter.

There is one overriding moral you get from this kind of testing: to transmit a clean signal, you need to avoid overdriving your transmitter. The LP-500 will show you how backing off, say 20 to 50% from maximum rated power, can really help. (And 20% less is only 1 dB, or 1/3 of an S-unit — less on the other station's receiver.)

PC Software

TelePost provides a *VM (virtual meter)* software application that runs under *Windows*. You simply connect your LP-500 with your PC via a standard USB cable. No special driver is required. This software is still under development, so not all the LP-500 data and controls are yet available on the PC.

A Few Comments

I had been grumbling to myself about the lack of a modern station monitor for some years, to the point where I

Lab Notes: TelePost LP-500

Bob Allison, WB1GCM, ARRL Assistant Laboratory Manager

When I first tested the LP-500, it typically read 120 W with 100 W applied on all HF bands. I contacted TelePost, and Larry Phipps, N8LP, wrote back promptly and explained:

The meter's negative power supply lead must be at the same potential as the rig chassis. If it isn't, there can be residual dc on the negative lead of the power cable that powers the meter during transmit. The reason for the increased reading is that the couplers use the rig's chassis as a ground reference (through the coax shields), whereas the meter ground reference comes from the power supply. If the meter ground is at -0.15 V dc compared to the couplers, then that essentially adds 0.15 V dc to the FWD and REF samples. That difference would add about 20 W to the FWD reading at 100 W. I touch on this on page 2 of the manual, where we talk about powering the meter, although I don't mention what could happen if there is inadequate bonding. I plan to update the manual to add this.

Sure enough, bonding grounds together with the negative lead of the meter's power cable made the meter read spot-on with the applied power.

Because I had adjusted the alignment of couplers while trying to find out why the power was reading high, we asked TelePost for another meter and couplers. They soon arrived, along with an isolated wall-type power supply. Using the isolated supply gave the same results as when using the bonding method. Lab tests shown in Table 2 were performed with the second unit, serial number 0325.

The Lab's test fixture consists of a TelePost LP-100 power meter, which was checked for accuracy against the Lab's HP-437B power sensor, used with attenuators, cables, and connectors of known attenuation, on each band tested. The LP-100 reads essentially the same as the HP-437B. Our HF SWR measurements were made using a resistive, nonreactive load box, built by ARRL Laboratory Technical Advisor, Phil Salas, AD5X.

thought of doing my own. So I am pleased to see the LP-500 on the market.

TelePost supplies an extensive *User Guide*, which carefully explains the capabilities of the LP-500 and shows how to use it in many different scenarios. The TelePost website gives the latest product news and revision downloads. Community support is available through the LP-500 Yahoo group (groups.yahoo.com/neo/groups/LP-500).

A techie like me would like more information on the design and implementation. Details on the application programming interface (API) that is exposed via the USB connection are available from TelePost, along with a sample Visual Basic program and source code for controlling and read-

ing data from the meter. Opening the box reveals that the LP-500 relies on PIC32 and a VLSI Solutions VS1000 processor for its smarts.

In my testing, I found that the LP-500's fixed audio output level can be too high or too low for easy interface to a particular radio. An adjustable output level and even a choice of balanced or unbalanced outputs would be helpful. TelePost says that an audio adapter device is in the works.

My fingers had some trouble with the touchscreen — for example, when I tried to place the cursors precisely. It does help to use some kind of stylus. You'd think the encoder knob should naturally adjust cursor positions, but currently, the knob only helps to compose your station ID string and to

adjust some sweep rates and to adjust a few other parameters.

One more small complaint was that while the LP-500 is very usable for modulation monitoring in a qualitative way, it does not automatically give some of the quantitative results. Visually checking for gross flat-topping is easy, but getting distortion numbers may require manually adjusting cursors and reading off values. This is fine for bench testing, but on the air, I would like to see live data, such as the real-time departure from linearity.

Summing up

Overall, the LP-500 is a fine product that will advance “good engineering and good amateur practice,” providing a lot of information about your transmitted signal and supporting a wide range of station setups. We can expect improvements as develop-

ment continues and new software revisions roll out.

Manufacturer: TelePost Inc., 49100 Pine Hill Dr., Plymouth, MI 48170; www.telepostinc.com. Price: LP-500 Digital Station Monitor (5-inch screen), \$650; LP-700 (7-inch

screen), \$720; LPC-501 HF/6 3kW PEP coupler, \$150; LPC-502 HF/6 5 kW PEP coupler, \$200; LPC-503 HF only 10 kW PEP coupler, \$200. (TelePost, like other small companies, has a low production volume that can lead to shipping delays. Check the shipping status when ordering.)



Visit <https://youtu.be/oWwTXCd-MQ0> to see our review of the TelePost LP-500 Digital Station Monitor on YouTube.