



RCI-X9

10 Meter Amateur Mobile Transceiver With Built-in Frequency Counter & Touch Select Multicolor



867 Bowsprit Road
Chula Vista, CA 91914
Email: sales@rangerusa.com
<http://www.rangerusa.com>

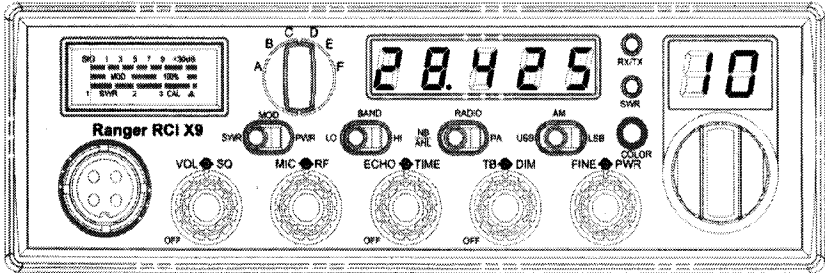

PRINTED IN MALAYSIA
A382007X9A

User's Manual

Table of Contents

	<u>PAGE</u>
Chapter 1 Specifications	2
Chapter 2 Introduction	3
Unpacking	3
Chapter 3 Installation	4
Transceiver Mounting	4
Power Connection	4
Chapter 4 Operation	5
Front Panel	5
Rear Panel	8
Press-To-Talk	9
Operating Procedure to Receive	9
Operating Procedure to Transmit	9
Alternate Microphone and Installation	10
Memo	13

Chapter 1 Specifications

GENERAL

Model	RCI-X9
Frequency Range	28.315-29.660MHz
Emission	USB, LSB, AM
Frequency Control	Phase-Lock-Loop Synthesizer
Frequency Tolerance	0.005%
Frequency Stability	0.001%
Operating Temperature Range	-20°C to +50°C
Antenna Impedance	50 ohm
Microphone	Plug-In dynamic; with push-to-talk switch and coiled cord
Meter Function	RF Output, RX Receive Signal Strength, SWR, AM Modulation
Input Voltage	13.8 V DC
Dimensions	7 3/8" (W) x 8 3/4" (D) x 2 1/4" (H)
Weight	5 lb. 8 oz.

TRANSMITTER

RF Power Output	AM : 30W RMS AM/SSB : 120W PEAK POWER
-----------------	--

RF Transmit Modes	USB, LSB, AM,
Antenna Connector	UHF Type, 50 Ω
Modulation	A3E, J3E,
Spurious Emissions	> -50 dB
Carrier Suppression	-50 dB

RECEIVER

Sensitivity	AM : 0.5 μV for 10dB Sinad SSB : 0.25 μV for 12dB Sinad
-------------	--

Image Rejection Ratio	> 50 dB
Audio Power Output	2.5W

(SPECIFICATIONS SUBJECT TO CHANGE WITHOUT NOTICE)

Chapter 2 Introduction

Congratulations on your purchase of an RCI-X9 10 meter band amateur radio. Your RCI-X9 is designed to provide trouble-free service and state-of-the-art communications, incorporating many useful features and functions in the 10 meter dual band radio. Please read this manual thoroughly to ensure proper performance.

IMPORTANT

*To operate this radio, you must possess an amateur radio operator's license issued by the FCC. Operation of this unit without proper licensing is **ILLEGAL** and can result in severe penalties.*

NOTE

The manufacturer is not responsible for any radio or TV interference caused by unauthorized modifications to this equipment. Such modifications could void the user's authority to operate this equipment.

Unpacking

The following items are included with our RCI-X9. Carefully remove and examine all materials from the packing carton. If any items are missing or appear damaged, please contact your dealer immediately. Each unit should include:

- (1) RCI-X9 Transceiver
- (2) Dynamic Microphone (SRA-198 NOISE CANCELLING MIC)
- (3) Power Cord
- (4) Mounting Bracket & Hardware
- (5) Installation Hardware
- (6) Owner's Manual

It is recommended that you save the packing materials for future storage or shipping.

Chapter 3 Installation

The RCI-X9 is easy to install. All necessary parts (less the antenna and coax cable) have been included to facilitate installation.

Transceiver Mounting

Choose a suitable location for the transceiver that will allow easy access to the front panel as well as proper air circulation to the back of the unit. If you are installing the unit in a vehicle, attach the mounting bracket first, and then attach the transceiver to the mounting bracket using the hardware provided. Before making any electrical connection, ensure that the transceiver is turned off and the vehicle's battery is disconnected.

Power Connection

The transceiver operates off of any 12 to 13.8 VDC source. Beware of voltage drops caused by operating from Cigarette Lighter Plugs or long DC wire runs. Sometimes it is best to connect direct to the battery for best RF output and TX audio quality

NOTE

*The condition of a vehicle's electrical system can affect the operation of your **RCI-X9**. A low battery, worn generator/alternator, or poor voltage regulator will impair performance of the unit as well as the vehicle.*

CAUTION

Voltage above 15 VDC will damage the unit. Be sure to check the source voltage before connecting the power cord.

Chapter 4 Operation

Front Panel

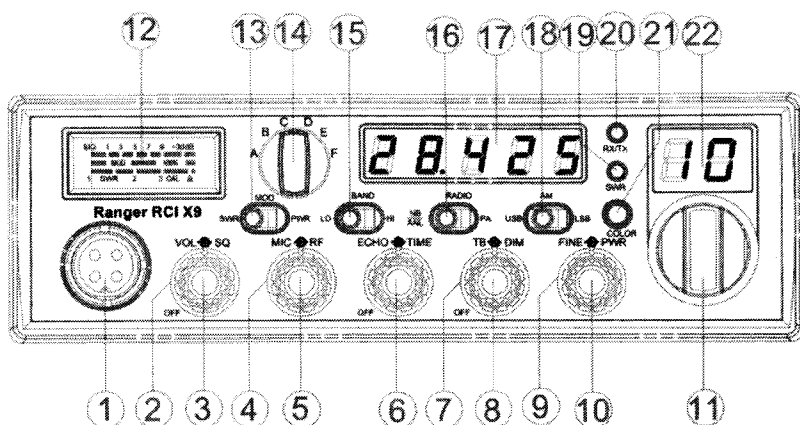

1. **MICROPHONE:** Used to connect microphone.

2. **SQUELCH:** This knob is used to eliminate background noise being heard through the receiver, which can be disturbing when no transmissions are being heard through the receiver. To use this feature, turn the knob fully counterclockwise and then turn clockwise slowly until the background noise is just eliminated. Further clockwise rotation will increase the threshold level that a signal must overcome in order to be heard. Only strong signals will be heard at a maximum clockwise setting.

3. **ON/OFF VOLUME:** This knob controls the volume and power to the radio. To turn radio on, rotate the knob clockwise. Turning the knob further will increase the volume of the receiver.

4. **RF GAIN:** Adjust this knob for desired level of incoming signal.

5. **MIC GAIN:** Adjusts the microphone gain in transmit and PA modes. This controls the gain to the extent that full talk power is available several inches away from the microphone. In the Public Address (PA) mode, the control functions as the volume control.

6. **ECHO/TIME CONTROL:** The ECHO control is used for echo effect. The TIME control is used to control the intervals of the echo sound.

Operation (Continued)

7. **DIM:** This knob controls the level of brightness for the meter lamp, frequency display, channel display and all the indicator LED's except the SWR warning light.

8. **TALKBACK/OFF CONTROL:** Adjust this knob for desired volume of Talkback. This is used to monitor your own voice. For example, you could use this feature to compare different microphones.

9. **PWR:** This control allows the user to adjust RF power output.

10. **FINE CONTROL :** Allows variation of the receive frequency above and below the selected receive frequency as shown on the display. This control is intended primarily to tune in SSB signals when communicating with several stations that may not be exactly on frequency. It may also be used to optimize AM/FM signals as described in the operating procedure paragraph. The clarifier can adjust the receive frequency $\pm 1.0\text{KHz}$ but does not affect the transmit frequency or the frequency display.

11. **CHANNEL SELECTOR:** This control is used to select the desired transmit and receive channel.

12. **FRONT PANEL METER:** The front panel meter allows the user to monitor incoming signal strength, RF output power, AM modulation and SWR level.

13. **SWR/MOD/POWER:** This switch controls the function of the meter during the transmit mode. In the "SWR" position, the meter indicates the Standing Wave Ratio (SWR) of the antenna (accurate at maximum power output). There are no adjustments because the SWR circuit in this radio calibrates itself automatically. When the switch is in the "MOD" position in the AM mode only. It is accurate when testing at maximum power output. When this switch is "PWR" position, the meter indicates your power output.

14. **BAND SELECTOR:** This switch is used to select the band.

15. **BAND SWITCH :** The band switch allow the user to select the HI or LO band.

16. **NB/ANL/RADIO/PA:** When the switch in NB/ANL position, the RF Noise Blanker and Automatic Noise Limiter circuit are active. The noise blanker is very effective for repetitive impulse noise such as ignition interference. In the PA position, the radio acts as a public address amplifier. Your voice will come out of the speaker that is plugged into the PA. SP. Jack on the rear panel. In the RADIO position, the PA function is disabled and the radio will transmit and receive on the speaker that is connected to the unit.

Operation (Continued)

17. FREQUENCY COUNTER: This display indicates the frequency of the selected channel.

18. MODE SWITCH : This control allows you to select one of the following operating modes: AM/USB/LSB.

19. SWR LED: This LED lights red to indicate an SWR that is higher than around 3:1. It is not an exact indicator of a 3:1 SWR. When it lights red, please check your SWR using the built in SWR circuit.

20. RX/TX LED: This LED lights red to indicate the unit is in the transmit mode. It lights blue to indicate the unit is in the receive mode.

21. COLOUR SWITCH: This touch switch allows you to select one of the seven backlight colors (blue, light blue, light red, orange, white, red, green). All faceplate lettering will fully illuminate to allow the user easy viewing at night. This unique, solid state, backlight is designed to maximize night vision while minimizing eye fatigue. Therefore, it is ideal for switch and control recognition day or night.

22. CHANNEL INDICATOR: Numbered LED indicates the selected channel you wish to operate on.

Operation (Continued)

Rear Panel

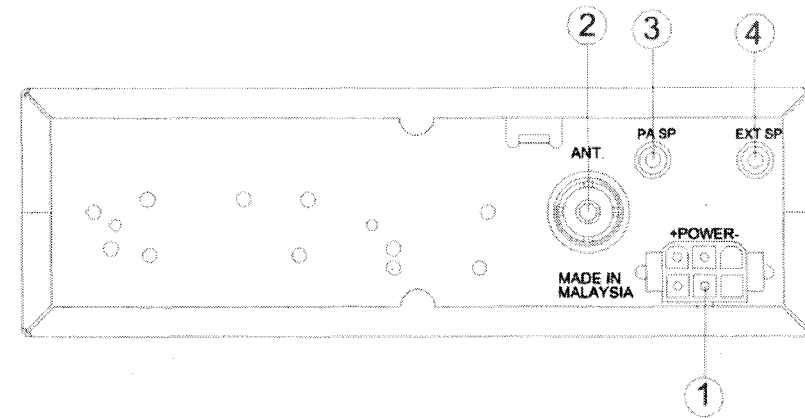

- 1. POWER:** This socket accepts a 13.8 VDC power cable with built-in fuse. The power cord provided with the radio consists of a black wire (negative) and a red wire (positive).
- 2. ANTENNA:** This jack accepts a 50 ohms coaxial cable with a PL-259 style plug.
- 3. PA SP.:** This jack is for public address operation. Before operating in the PA mode, you must first connect a PA speaker (8 Ohms, 4W, 1/8" or 3.5mm diameter plug) to this jack.
- 4. EXTERNAL SPEAKER:** This jack accepts a 4 - 8 ohm 5W external speaker. When an external speaker is connected to this jack, the built-in speaker is disabled.

Operation (Continued)

PRESS-TO-TALK MICROPHONE

The receiver and transmitter are controlled by the press-to-talk switch on the microphone. Press the switch and the transmitter is activated, release switch to receive. When transmitting, hold the microphone two inches from the mouth and speak clearly in a normal "voice". The radios come complete with low-impedance (500 ohm) dynamic microphone. For installation instruction on other microphones, see next section, "ALTERNATE MICROPHONES AND INSTALLATION".

OPERATING PROCEDURE TO RECEIVE

1. Be sure that power source, microphone and antenna are connected to the proper connectors before going to the next step.
2. Turn unit on by tuning **VOL** control clockwise on your transceiver.
3. Set the **VOLUME** for a comfortable listening level.
4. Set the **MODE** switch to the desire mode.
5. Listen to the background noise from the speaker. Turn the **SQUELCH** control slowly clockwise until the noise **JUST** disappears (no signal should be present). Leave the control at this setting. The **SQUELCH** is now properly adjusted. The receive will remain quiet until a signal is actually received. Do not advance the control too far, or some of the weaker signals will not be heard.
6. Set **CHANNEL** selector switch to the desired channel.
7. Set the **RF** gain control fully clockwise for maximum **RF** gain.

OPERATING PROCEDURE TO TRANSMIT

1. Select the desired channel of transmission.
2. Set the **MIC GAIN** control fully clockwise.
3. If the channel is clear, depress the push-to-talk switch on the microphone and speak in a normal voice.

Operation (Continued)

ALTERNATE MICROPHONES AND INSTALLATION

For best results, the user should select a low-impedance dynamic type microphone or a transistorized microphone. Transistorized type microphones have a low output impedance characteristic. The microphones must be provided with a four-lead cable. The audio conductor and its shielded lead comprise two of the leads. The fourth lead is for receive control, and the third is for transmit control. The microphone should provide the functions shown in schematic below.

4 WIRE MIC CABLE

Pin Number	Mic Cable Lead
1	Audio shield
2	Audio Lead
3	Transmit control
4	Receive Control

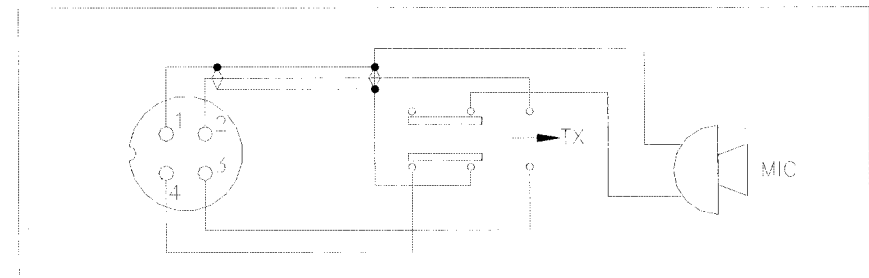

Fig. 1 Your transceiver microphone schematic.

If the microphone to be used is provided with pre-cut leads, they must be revised as follows.

1. Cut leads so that they extend 7/16" beyond the plastic insulating jacket of the microphone cable.
2. All leads should be cut to the same length. Strip the ends of each wire 1/8" and tin the exposed wire.

Before beginning the actual wiring read carefully, the circuit and wiring information provided with the microphone you select. Use the minimum heat required in soldering the connections. Keep the exposed wire lengths to a minimum to avoid shorting when the microphone plug is reassembled

Operation (Continued)

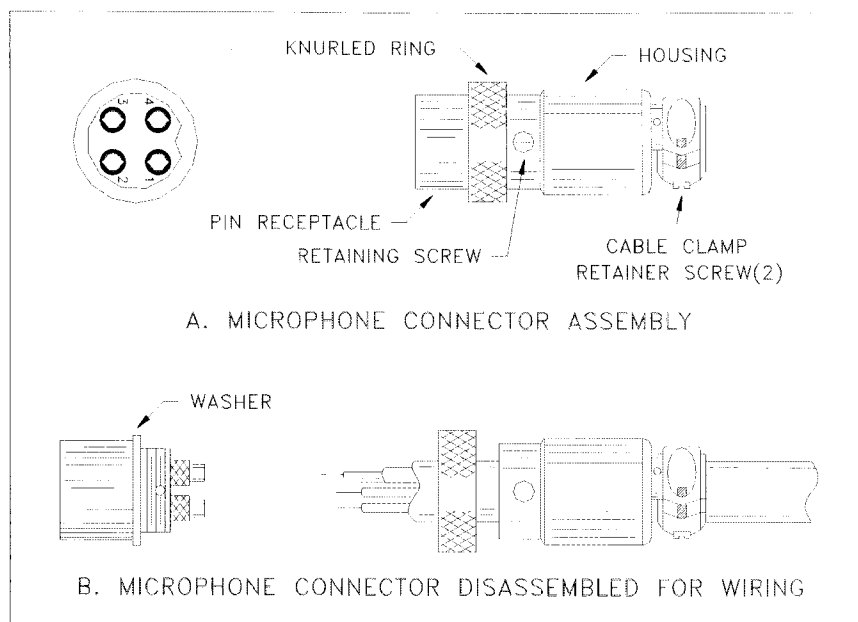

Fig. 2 Microphone plug wiring

1. Remove the retaining screw
2. Unscrew the housing from the pin receptacle body
3. Loosen the two cable clamp retainer screws.
4. Feed the microphone cable through the housing, knurled ring and washer as shown Fig. 2.

The wires must now be soldered to the pins as indicated in the above wiring tables. If a vise or clamping tool is available it should be used to hold the pin receptacle body during the soldering operation, so that both hands are free to perform the soldering. If a vise or clamping tool is not available, the pin receptacle body can be held in a stationary position by inserting it into the microphone jack of the front panel. The numbers of the pins of the microphone plug are shown in Fig. 3, as viewed from the back of the plug. Before soldering the wire to the pins, pre-tin the wire receptacle of each pin of the plug.

Operation (Continued)

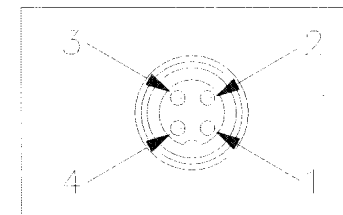

Fig. 3 Microphone plug pin numbers viewed from rear of pin receptacle.

Be sure that the housing and the knurled ring of Fig. 2 are pushed back onto the microphone cable before starting to solder. If the washer is not captive to the pin receptacle body, make sure that it is placed on the threaded portion of the pin receptacle body before soldering.

If the microphone jack is used to hold the pin receptacle during the soldering operation, best results are obtained when the connections to pins 1 and 3 are made first and then the connections to pins 2 and 4. Use a minimum amount of solder and be careful to prevent excessive solder accumulation on pins, which could cause a short between the pin and the microphone plug housing.

5. When all soldering connections to the pins of the microphone plug are complete, push the knurled ring and the housing forward and screw the housing onto the threaded portion of the pin receptacle body. Note the location of the screw clearance hole in the plug housing with respect to the threaded hole in the pin receptacle body. When the housing is completely threaded into the pin receptacle body, a final fraction of a turn either clockwise or counterclockwise may be required to align the screw hole with the threaded hole in the pin receptacle body. When these are aligned, the retaining screw is then screwed into the place to secure the housing to the pin receptacle body.
6. The two cable clamp retainer screws should now be tightened to secure the housing to the microphone cord. If the cutting directions have been carefully followed, the cable clamp should secure to the insulating jacket of the microphone cable.
7. Upon completion of the microphone plug wiring, connect and secure the microphone plug in the transceiver.

Memo

Memo

Memo

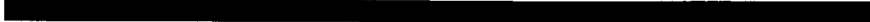

15 horizontal lines for writing.

Memo

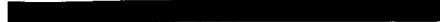

15 horizontal lines for writing.