

Mirage

MX-36HP

AM 10 Meter Amateur Mobile Transceiver

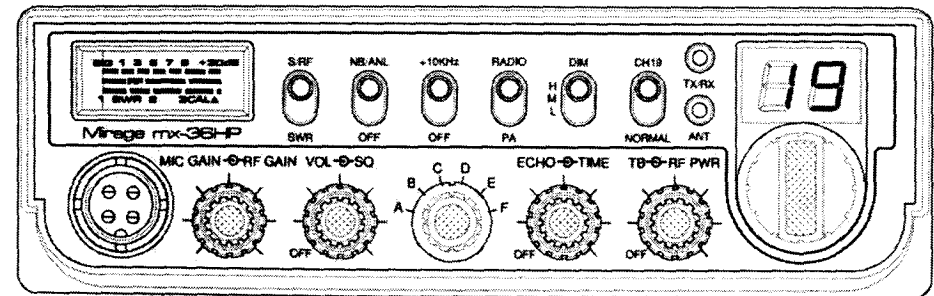

User's Manual

Printed in Vietnam
P/N:A38200744V

CONTENTS

	PAGE
Specifications	2
Installation	3
Installing The Radio	3
Ignition Noise Interference	4
Antenna	4
External Speaker	4
Public Address	4
Operation	5
Front Panel	5
Rear Panel	7
Procedure to Receive And Transmit	8
Alternate Microphone And Installation	9

SPECIFICATIONS

GENERAL

Model	MX-36HP
Frequency Range	28.145 ~ 28.575 MHz
Emission	AM
Frequency Control	Phase-Lock-loop (PLL) Synthesizer
Frequency Stability	0.001%
Temperature Range	-20°C to +50°C
Antenna Impedance	50 Ohms
Antenna Connectors	Standard SO-239 type
Input Voltage	13.8V DC
Size	7- 3/8" (W) x 8- 3/4" (D) x 2- 1/4" (H)
Weight	4.2 lbs.

TRANSMITTER

RF Power Output	AM : 10W
Spurious Emission	> -50 dB
Audio Distortion	< 10%
Frequency Response	300 to 2500 Hz
Microphone	Dynamic

RECEIVER

Sensitivity	AM: 0.5 uV for 10dB Sinad
Squelch Sensitivity	< 0.5 uV
Image Rejection	> 50 dB
Audio Power Output	3W @ 10% Distortion
Audio Response	300 to 2500 Hz

(SPECIFICATIONS SUBJECT TO CHANGE WITHOUT NOTICE)

INSTALLATION

INSTALLING THE RADIO

Choose a convenient location for operation that does not interfere with driver or passenger. This radio is supplied with a universal mounting bracket. When mounting the bracket and radio to your car, make sure it is mechanically strong. Also, provide a good electrical grounding connection to the chassis of vehicle. Proceed as follows to install the radio.

1. Locate a convenient area in your vehicle for the installation of the radio. Hold the mounting bracket with the radio in the location where the radio is to be installed. Make sure nothing will interfere with either the radio or the mounting bolts. Mark and then drill holes for the mounting bracket.
2. Most radio antennas come equipped with a PL-259 plug. Connect this plug to the ANT. Jack in the rear of the radio.
3. Extending from the rear of the radio is a fused red and black wire for the DC connections to the vehicle's electrical system. For best performance, it is strongly recommended that the red lead be taken directly to the positive terminal on the vehicle's battery and the black lead be connected to the nearest chassis ground. (Note: ***This radio is designed for vehicles with negative ground systems.***)

Connections should be made using appropriate "crimp on" lugs of a size large enough to make good contact with the bolt used to fasten to the battery and the chassis ground. It is a good safety idea to install a second fuse that would provide protection in case the red wire was to "fray" or get pinched and short to the body of the vehicle, somewhere between the battery and the radio.

High power radios such as this one require large DC current flow when in the TX mode. Poor power connections will cause supply voltage drops that can substantially decrease the performance of your radio. A good DC connection is probably one of the most important things for getting the best transmitter performance and in some cases, least receiver noise.

4. Mount the microphone bracket near the radio in an easily accessible spot using the two screws provided.

OPERATION

IGNITION NOISE INTERFERENCE

With weak signals, you may experience interference of the signal by background noise. This radio has NB and ANL circuits that will help reduce background noise from sources such as your ignition system. However, background electrical noise may come from several sources and all noise may not be eliminated. With extremely weak signals, you can operate this radio with the engine turned off, which should improve reception. If the ignition noise level is too high to allow proper operation under most conditions, you should have your installation of the radio checked by a qualified technician.

ANTENNA

This radio has a jack in the rear for a standard PL-259 antenna plug. If you are looking for the most range for your transmission, use a vertically polarized, quarter-wave length antenna. If antenna height is a problem, you may use a shorter, loaded-type whip antenna although you can expect some loss of transmission range.

To improve performance, your antenna should be matched to your radio. Your antenna can be adjusted so that it matches your radio.

EXTERNAL SPEAKER

The external speaker jack (EXT SP.) on the rear panel is used for remote receiver monitoring. The external speaker should have 8 ohms impedance and be able to handle at least 4 watts. When the external speaker is plugged-in, the internal speaker is disconnected.

PUBLIC ADDRESS

To use the Public Address (PA) function, first connect an external speaker to the PA. SP. Jack on the rear of the radio. See the above specifications for a proper external speaker. Keep the speaker away from the microphone to avoid acoustic feedback.

OPERATION

FRONT PANEL

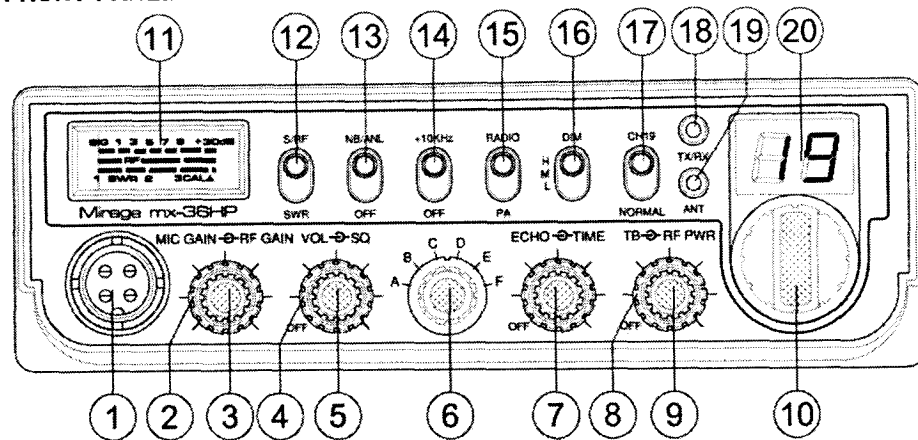

1. **MICROPHONE JACK:** Used for connecting a microphone for voice source.
2. **RF GAIN CONTROL:** This control is used to reduce the gain of the RF amplifier under strong signal conditions.
3. **MIC GAIN CONTROL:** Adjust the microphone gain in the transmit and PA modes. This controls the gain to the extent that full talk power is available several inches away from the microphone. In the Public Address (PA) mode, the control functions as the volume control.
4. **SQUELCH CONTROL:** This switch is used to eliminate background noise being heard through the receiver, which can be disturbing when no transmission is being heard through the receiver. To use this feature, turn the switch fully counterclockwise and then turn clockwise slowly until the background noise is just eliminated. Further clockwise rotation will increase the threshold level of which a signal must overcome in order to be heard. Only strong signal will be heard at a maximum clockwise setting.
5. **ON/OFF VOLUME CONTROL:** This knob controls the volume and power to the radio. To turn radio on, rotate the knob clockwise. Turning the knob further will increase the volume of the receiver.
6. **BAND SELECTOR:** This switch allows the user to select the frequency range of the channel selector.

OPERATION

7. **ECHO/TIME CONTROL:** The ECHO control is used for echo effect. The TIME control is used to control the intervals of the echo sound.
8. **RF POWER CONTROL:** This control enables adjustment of RF power output continuously up to the rated output power.
9. **TALKBACK/OFF CONTROL:** Adjust this knob for desired volume of Talkback. This is used to monitor your own voice. For example, you could use this feature to compare different microphones.
10. **CHANNEL SELECTOR:** This control is used to select a desired transmit and receive channel.
11. **FRONT PANEL METER:** The Front Panel Meter allows the user to monitor signal strength, RF output power and SWR level.
12. **S-RF/SWR SWITCH:** In the S-RF position, the meter swings Proportionally to the strength of the received signal. When transmitting the meter indicates relative RF output power. When in the SWR position, the Standing Wave Ratio (SWR) of your antenna. There are no adjustments because the SWR circuit this radio calibrates itself automatically
13. **NB/ANL/OFF SWITCH:** In the NB/ANL position, the RF Noise Blanker and the automatic Noise Limiter in the audio circuits are also activated. The Noise Blanker is very effective in eliminating repetitive impulse noise such as ignition interference.
14. **+10 KHz/OFF SWITCH:** In the +10 KHz position, the transmit and receive frequency is shifted 10 KHz up.
15. **PA / RADIO SWITCH:** Select the mode of operation. In the PA position, the radio acts as public address amplifier. Your voice will come out of the speaker that is plugged into the PA. SP. jack on the rear panel. The radio does not operate when you are in the PA mode. In the RADIO position, the PA function is disabled and the radio will transmit and receive on the speaker that is connected.
16. **DIM. H/M/L:** Controls the brightness of the meter, channel display, band display, RX/TX LED, ANT LED and backlight color.
17. **CH19/NORMAL SWITCH:** Channel 19 switch is used for instant access to information channel 19.
18. **TX/RX LED:** The red LED indicates the unit is in the transmit mode. The Blue LED indicates the unit is in the receive mode.

OPERATION

- 19. ANT LED:** This LED lights red when your SWR is higher than about 3:1. This is not an exact indicator of 3:1 SWR, but it is an indication that you should check your antenna and its components.
- 20. CHANNEL DISPLAY:** The channel display indicates the current selected channel.

REAR PANEL

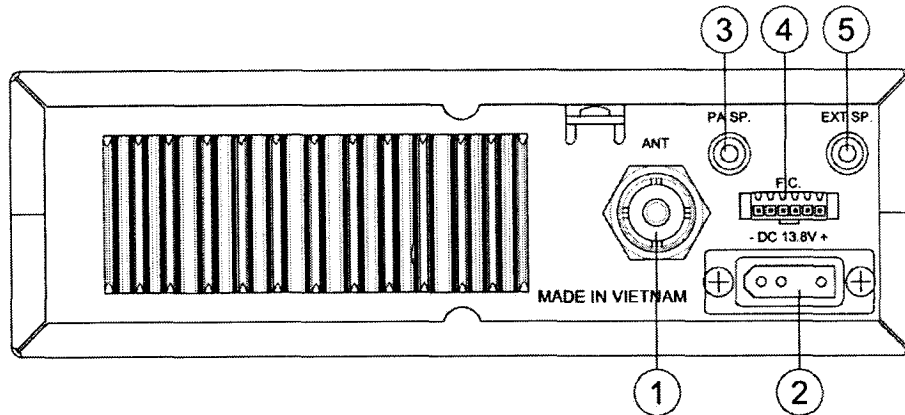

- 1. ANTENNA:** This jack accepts 50 ohms coaxial cable with a PL-259 type plug.
- 2. DC POWER:** This accepts 13.8V DC power cable with built-in fuse. The power cord provided with the radio has a black and red wire. The black goes to negative and red goes to positive.
- 3. PA SP:** This jack is for PA operation. Before operating, you must first connect a PA speaker (8 ohms, 4W) to this jack.
- 4. F.C.:** This connector is used for connecting an external frequency counter, which indicates the frequency of the selected channel.
- 5. EXT. SP:** This jack accepts 4 to 8 ohms external speaker. When the external speaker is connected to this jack, the built-in speaker will be disabled.

OPERATION

PROCEDURE TO RECEIVE AND TRANSMIT

A. MICROPHONE

The push-to-talk switch on the microphone controls the receiver and transmitter. Press the switch and the transmitter is activated, release switch to receive. When transmitting, hold the microphone close to the mouth and speak clearly in a normal voice. This transceiver comes complete with a low impedance Noise cancelling dynamic microphone.

B. PROCEDURE TO RECEIVE

1. Be sure that power source, microphone and antenna are connected to the proper connectors before going to the next step.
2. Turn **VOL** knob clockwise to apply power to the radio.
3. Set the **VOL** for a comfortable listening level.
4. Set the **MODE** switch to the desired mode.
5. Listen to the background noise from the speaker. Turn the **SQ** knob slowly clockwise until the noise just disappears. The **SQ** is now properly adjusted. The receiver will remain quiet until a signal is actually received. Do not advance the control too far or some of weaker signals will not be heard.
6. Set the **CHANNEL** selector switch to the desired channel.
7. Set the **RF GAIN** control clockwise for maximum RF gain.

C. PROCEDURE TO TRANSMIT

1. Select the desired channel of transmission
2. Set the **MIC GAIN** control fully clockwise.
3. If the channel is clear, press the push-to-talk switch on the microphone and speak in a normal voice.

OPERATION

ALTERNATE MICROPHONES AND INSTALLATION

For best results, the user should select a low-impedance dynamic type microphone or a transistorized microphone. Transistorized type microphones have low output impedance characteristics. The microphones must be provided with a four-lead cable. The audio conductor and its shielded lead comprise two of the leads. The third lead is for transmit control and fourth is for receiving control.

The microphone should provide the functions shown in schematic below.

4 WIRE MIC CABLE

<u>Pin Number</u>	<u>Mic Cable Lead</u>
1	Audio Shield
2	Audio Lead
3	Transmit Control
4	Receive Control

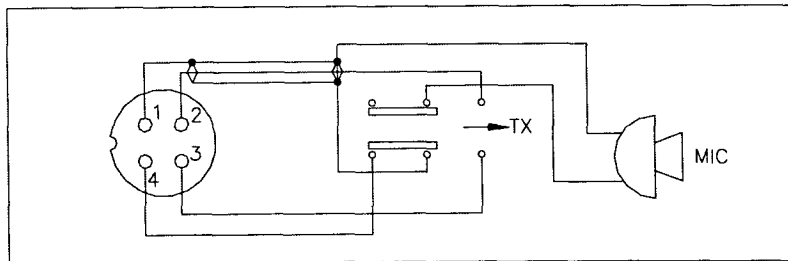

Fig. 1 Transceiver Microphone Schematic Diagram

If the microphone to be used is provided with pre-cut leads, they must be revised as follows.

1. Cut leads so that they extend 7/16" beyond the plastic insulating jacket of the microphone cable.
2. All leads should be cut to the same length. Strip the ends of each wire 1/8" and tin the exposed wire.

Before beginning the actual wiring, read carefully the circuit and wiring information provided with the microphone you select. Use the minimum heat required in soldering the connections. Keep the exposed wire lengths to a minimum to avoid shorting when the microphone plug is reassembled.

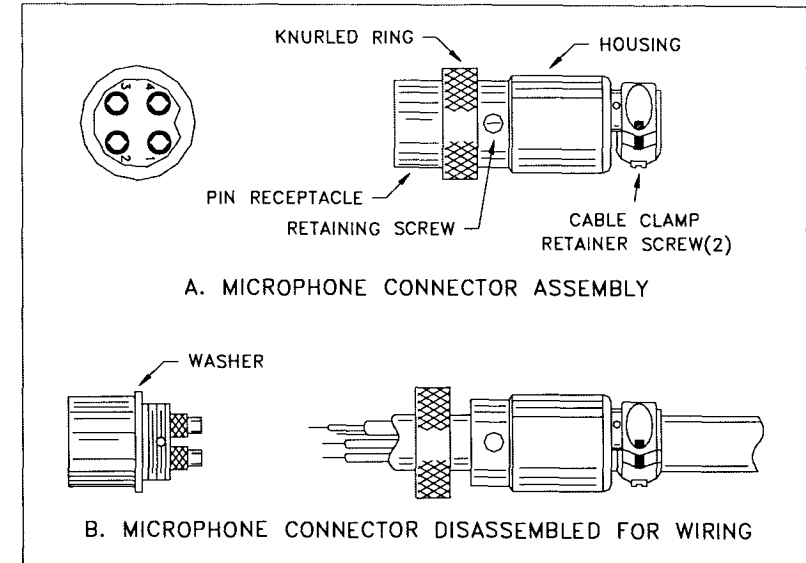

Fig. 2 Microphone plug wiring

To wire the microphone cable to the plug provided, proceed as follows:

1. Remove the retaining screw.
2. Unscrew the housing from the pin receptacle body.
3. Loosen the two cable clamp retainer screws.
4. Feed the microphone cable through the housing, knurled ring as shown Figure 2.
5. The wires must now be soldered to the pins as indicated in the above wiring tables. If a vise or clamping tool is available, it should be used to hold the pin receptacle body during the soldering operation, so that both hands are free to perform the soldering. If a vise or clamping tool is not available, the pin receptacle body can be held in a stationary position by inserting it into the microphone jack on the front panel. The numbers of the microphone plug

