



INSTALLATION INSTRUCTIONS FOR PART 95-9011

Volkswagen multi-kit 2005-up 95-9011



KIT FEATURES

- Double DIN radio provision

KIT COMPONENTS

- A) Radio Housing • B) DDIN Brackets • C) DDIN Trim Plate

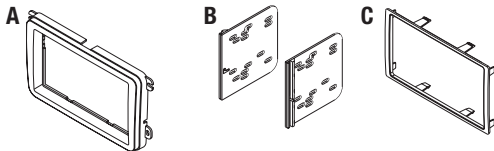

WIRING & ANTENNA CONNECTIONS (sold separately)

Wiring Harness: • XSVI-9003-NAV VW Interface 2002-up

Antenna Adapter: • 40-EU55-adapter for amplified antenna 2002-up • 40-EU56 antenna adapter

TOOLS REQUIRED

- Panel removal tool • Phillips screwdriver • Socket Wrench

Applications

Beetle	2012-up
CC	2009-up
Eos	2007-up
Jetta GLI	2008-up
GTI	2006-up
Golf, Golf R	2010-up
Jetta	2005-up
Jetta SportWagen	2010-up
Passat	2006-up
R32	2007-2008
Rabbit	2007-2009
Tiguan	2009-up

CAUTION: Metra recommends disconnecting the negative battery terminal before beginning any installation. All accessories, switches, and especially air bag indicator lights must be plugged in before reconnecting the battery or cycling the ignition.

NOTE: Refer to the instructions included with the aftermarket radio.

Table of Contents

Dash Disassembly

- Jetta GLI 2008-20102
- GTI 2006-20092
- New Jetta 2005-20102
- Rabbit 2007-20092
- R32 2007-20082
- CC 2009-up3
- Passat 2006-20103
- Passat 2012-up3
- Jetta SportWagen 2010-up3
- Jetta 2011-up3
- Jetta GLI 2012-up3
- GTI 2010-up3
- Golf, Golf R 20103
- Tiguan 2009-up4
- Eos 2007-up4
- Beetle 2012-up5

Kit Assembly

- Double DIN radio provision6

Dash Disassembly

**New Jetta 2005-2010,
Jetta GLI 2008-2010, GTI 2006-2009
Rabbit 2007-2009, R32 2007-2008**

1. Unclip and remove the grille from the top-center of dash. (Figure A)
2. Remove one T-20 Torx screw from black insert from under grille removed in step one. (Figure B)
3. Remove insert. (Figure C)
4. Remove two T-20 Torx screws from under black insert removed in step two. (Figure D)

Continued on next page

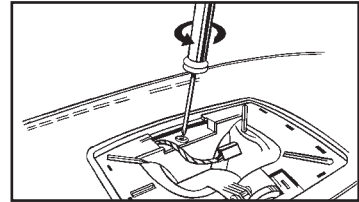

(Figure B)

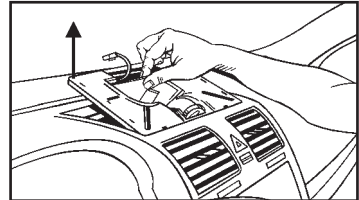

(Figure C)

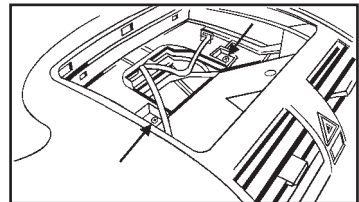

(Figure D)

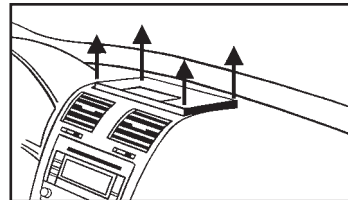

(Figure A)

Dash Disassembly

Continued from page 2

5. Unclip and remove the grille from the top-center of dash. (Figure E)
6. Remove one T-20 Torx screw from black insert from under grille removed in step one. (Figure F)
7. Remove insert. (Figure G)
8. Remove two T-20 Torx screws from under black insert removed in step two. (Figure H)

Continue to kit assembly

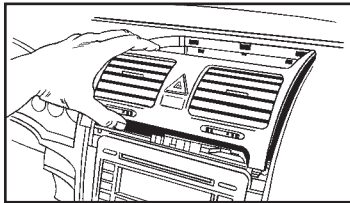

(Figure E)

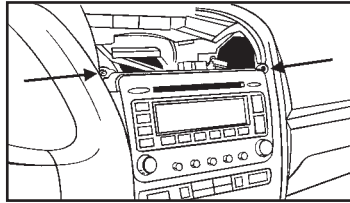

(Figure F)

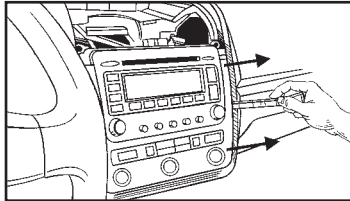

(Figure G)

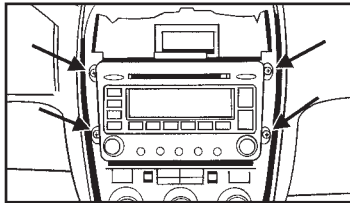

(Figure H)

**CC 2009-up, Passat 2006-2010,
Jetta SportWagen 2010-up,
Jetta 2011-up, Golf, Golf R 2010,
GTI 2010-up**

1. Unclip and remove trim panel surrounding radio. (Figure A)
2. Remove (4) T-20 Torx screws to remove radio.

Continue to kit assembly

Jetta GLI 2012-up

1. Unclip and remove trim panel surrounding radio. (Figure B)
2. Remove (4) T-20 Torx screws to remove radio.

Continue to kit assembly

Passat 2012-up

1. Unclip and remove trim panel surrounding radio. (Figure C)
2. Remove (4) T-20 Torx screws to remove radio.

Continue to kit assembly

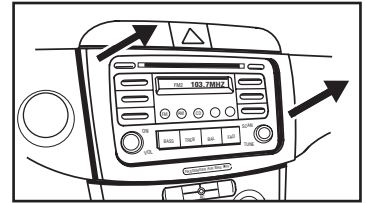

(Figure A)

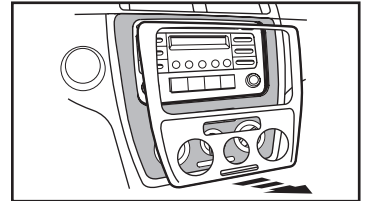

(Figure B)

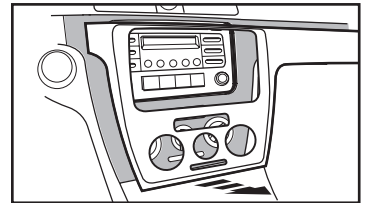

(Figure C)

Dash Disassembly

Tiguan 2009-up

1. Unclip and remove passenger air bag light panel to the right of the hazard light button. (Figure A)
2. Unclip and remove the panel with the two slots in it to the left of the hazard light button. (Figure A)
3. Remove (2) T-20 Torx screws exposed behind the two panels removed in the two previous steps. (Figure B)
4. Unclip and remove the trim panel surrounding the radio. (Figure C)
5. Remove (4) T-20 Torx screws securing the radio. Unplug and remove the radio. (Figure D)

Continue to kit assembly

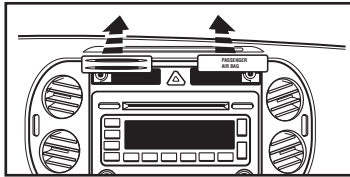

(Figure A)

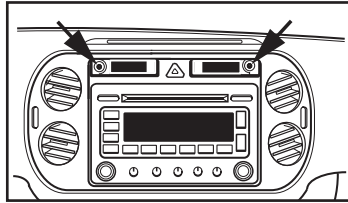

(Figure B)

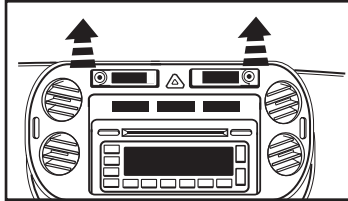

(Figure C)

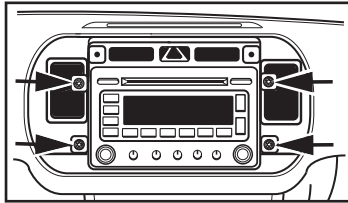

(Figure D)

Eos 2007-up

1. Unclip and remove the radio trim panel. (Figure A)

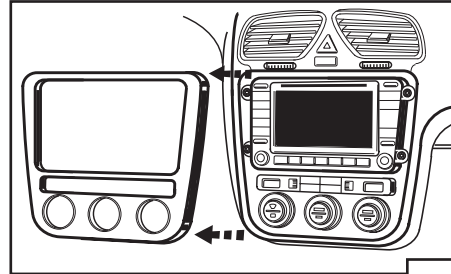

(Figure A)

2. Remove the (4) screws securing the radio. Unplug and remove the radio. (Figure B)

Continue to kit assembly

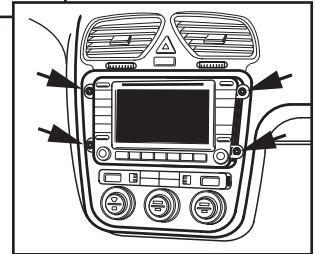

(Figure B)

Dash Disassembly

Beetle 2012-up

1. Unclip and remove the small trim around radio. (Figure A)
2. Unclip and remove larger trim around radio including the a/c vents. (Figure B)
3. Remove (4) Torx screws securing radio to remove the radio. (Figure C)

Continue to kit assembly

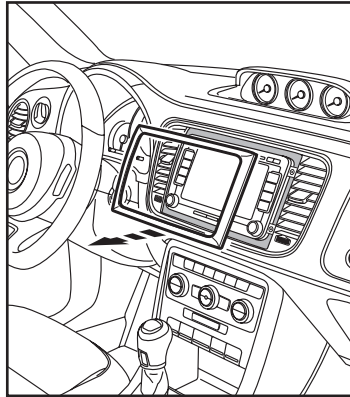

(Figure A)

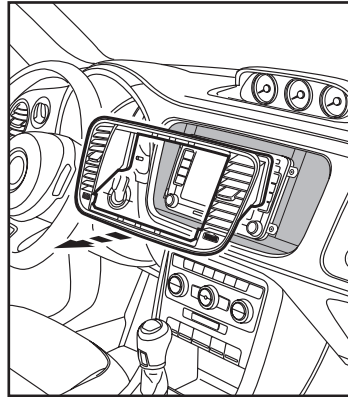

(Figure B)

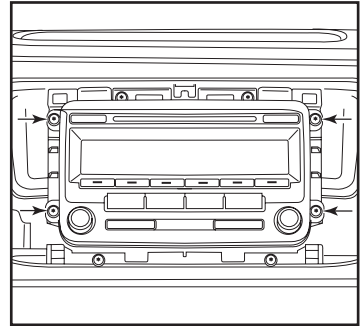

(Figure C)

Kit Assembly

Double DIN radio provision

1. Snap the DDIN brackets to the inside edge of the radio housing. (Figure A)
2. Slide the DDIN radio into the DDIN bracket/radio housing assembly and secure the radio to the kit using the screws supplied with the radio. (Figure B)
3. Snap the DDIN trim-plate onto the housing/radio assembly. (Figure B)
4. Locate the factory wiring harness in the dash. Metra recommends using the proper mating adapter from Metra or AXXESS. Re-connect the negative battery terminal and test the radio for proper operation.
5. Reassemble dash in reverse order of disassembly.

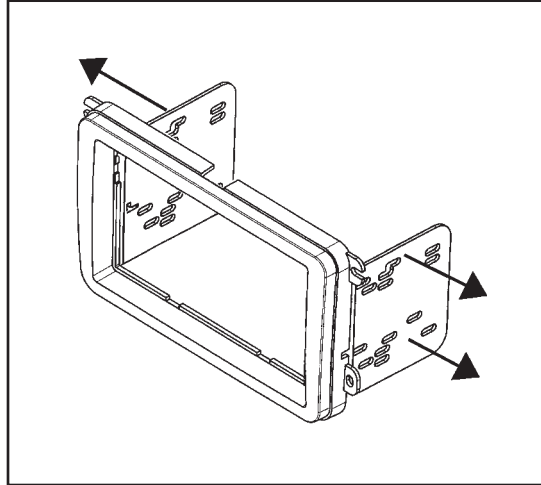

(Figure A)

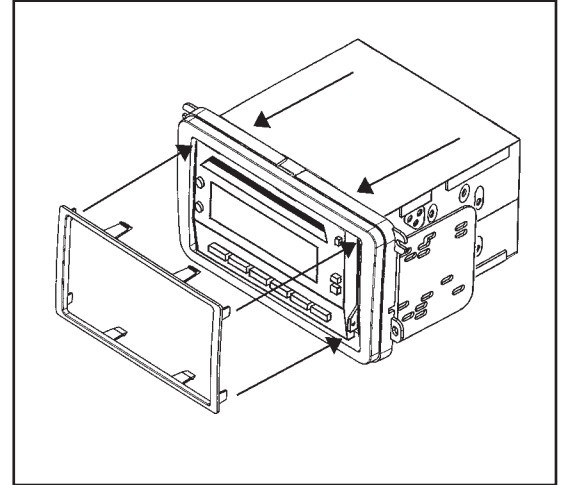

(Figure B)



INSTALLATION INSTRUCTIONS FOR PART 95-9011



REV 12/17/2013 INST95-9011



KNOWLEDGE IS POWER

Enhance your installation and fabrication skills by enrolling in the most recognized and respected mobile electronics school in our industry. Log onto www.installerinstitute.com or call 800-354-6782 for more information and take steps toward a better tomorrow.



Metra recommends MECP certified technicians



INSTRUCCIONES DE INSTALACIÓN PARA LA PIEZA 95-9011

Volkswagen multi-kit 2005 y mas 95-9011



CARACTERÍSTICAS DEL KIT

- Provisión de radio doble DIN

COMPONENTES DEL KIT

- A) Carcasa del radio • B) Soportes DDIN • C) Placa de moldura DDIN

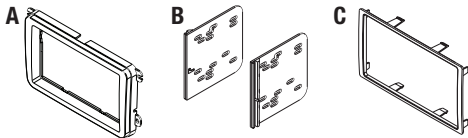

CABLEADO Y CONEXIONES DE ANTENA (se venden por separado)

Arnés de cableado: • Interfase VW XSVI-9003-NAV 2002 y mas •

Adaptador de antena: • 40-EU55 - adaptador para antena amplificada 2002 y mas • 40-EU56 adaptador para antena

HERRAMIENTAS REQUERIDAS

- Herramienta para quitar paneles • Destornillador Phillips • Llave para dados

Aplicaciones

Beetle	2012 y mas
CC	2009 y mas
Eos	2007 y mas
Jetta GLI	2008 y mas
GTI	2006 y mas
Golf, Golf R	2010 y mas
Jetta	2005 y mas
Jetta SportWagen	2010 y mas
Passat	2006 y mas
R32	2007-2008
Rabbit	2007-2009
Tiguan	2009 y mas

PRECAUCIÓN: Metra recomienda desconectar el terminal negativo de la batería antes de comenzar cualquier instalación. Todos los accesorios, interruptores y, especialmente, las luces indicadoras de airbag deben estar enchufados antes de volver a conectar la batería o comenzar el ciclo de ignición.

Nota: Remítase a las instrucciones incluidas con el radio de posventa.

Indice

Desmontaje del tablero

– Jetta GLI 2008-2010	2
– GTI 2006-2009	2
– New Jetta 2005-2010	2
– Rabbit 2007-2009	2
– R32 2007-2008	2
– CC 2009 y mas	3
– Passat 2006-2010	3
– Passat 2012y mas	3
– Jetta SportWagen 2010y mas	3
– Jetta 2011y mas	3
– Jetta GLI 2012y mas	3
– GTI 2010y mas	3
– Golf, Golf R 2010	3
– Tiguan 2009y mas	4
– Eos 2007y mas	4
– Beetle 2012y mas	5

Ensamble del kit

– Provisión de radio doble DIN	6
--------------------------------------	---

Desmontaje del tablero

**New Jetta 2005-2010,
Jetta GLI 2008-2010, GTI 2006-2009
Rabbit 2007-2009, R32 2007-2008**

1. Desenganche y quite la rejilla del centro superior del tablero. (Figura A)
2. Quite el tornillo Torx T-20 del inserto negro debajo de la rejilla que quitó en el paso uno. (Figura B)
3. Quite el inserto. (Figura C)
4. Quite los dos tornillos Torx T-20 de abajo del inserto negro que quitó en el paso dos. (Figura D)

Continúa en la siguiente página.

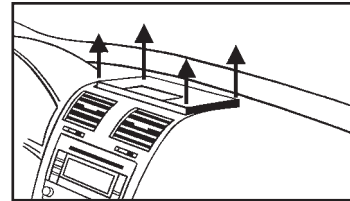

(Figura A)

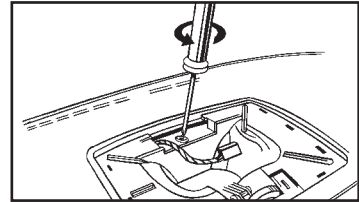

(Figura B)

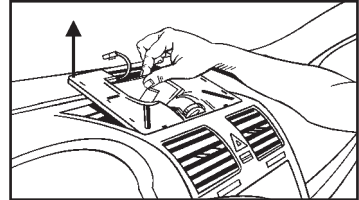

(Figura C)

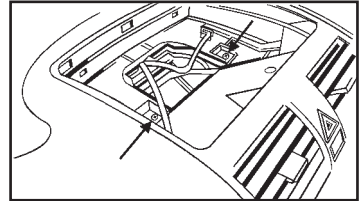

(Figura D)

Desmontaje del tablero

Viene de la página 2

5. Desenganche y quite la rejilla del centro superior del tablero. (Figura E)
6. Quite el tornillo Torx T-20 del inserto negro debajo de la rejilla que quitó en el paso uno. (Figura F)
7. Quite el inserto. (Figura G)
8. Quite los dos tornillos Torx T-20 de abajo del inserto negro que quitó en el paso dos. (Figura H)

Continúe con el ensamble del kit

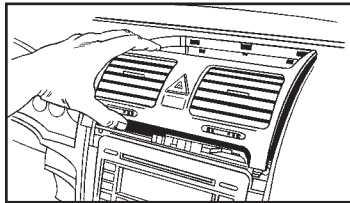

(Figura E)

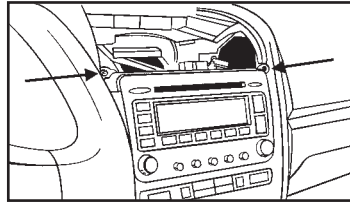

(Figura F)

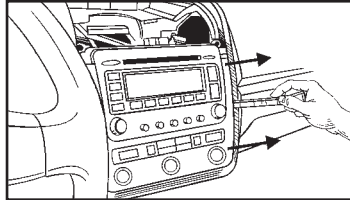

(Figura G)

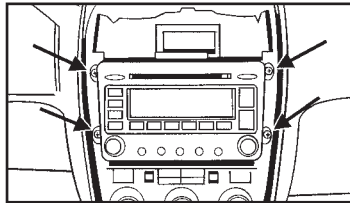

(Figura H)

CC 2009 y mas, Passat 2006-2010, Jetta SportWagen 2010 y mas, Jetta 2011y mas, Golf, Golf R 2010, GTI 2010y mas

1. Desenganche y quite el panel de la moldura que rodea el radio. (Figura A)
2. Quite los (4) tornillos Torx T-20 para quitar el radio.

Continúe con el ensamble del kit

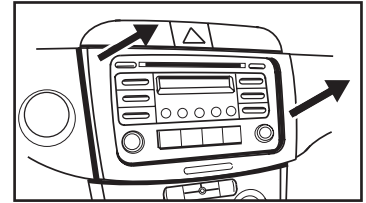

(Figura A)

Jetta GLI 2012 y mas

1. Desenganche y quite el panel de la moldura que rodea el radio. (Figura B)
2. Quite los (4) tornillos Torx T-20 para quitar el radio.

Continúe con el ensamble del kit

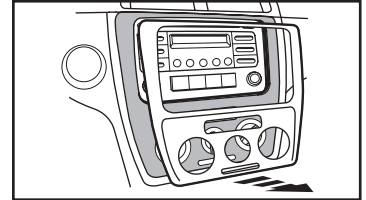

(Figura B)

Passat 2012 y mas

1. Desenganche y quite el panel de la moldura que rodea el radio. (Figura C)
2. Quite los (4) tornillos Torx T-20 para quitar el radio.

Continúe con el ensamble del kit

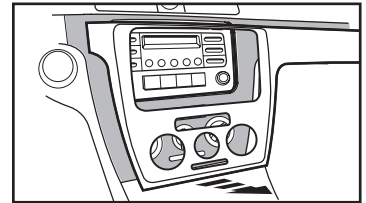

(Figura C)

Desmontaje del tablero

Tiguan 2009 y mas

1. Desenganche y quite el panel del foco de la bolsa de aire del pasajero a la derecha del botón de las luces intermitentes. (Figura A)
2. Desenganche y quite el panel que tiene dos ranuras a la izquierda del botón de las luces intermitentes. (Figura A)
3. Quite los (2) tornillos Torx T-20 expuestos detrás de los dos paneles que quitó en los dos pasos anteriores. (Figura B)
4. Desenganche y quite el panel de moldura que rodea el radio. (Figura C)
5. Quite los (4) tornillos Torx T-20 que sujetan el radio. Desconecte y quite el radio. (Figura D)

Continúe con el ensamble del kit

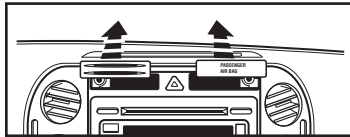

(Figura A)

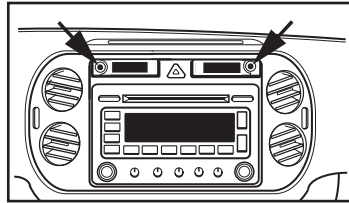

(Figura B)

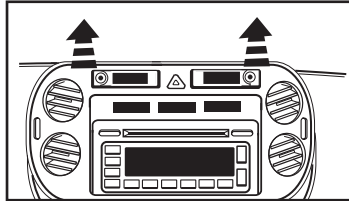

(Figura C)

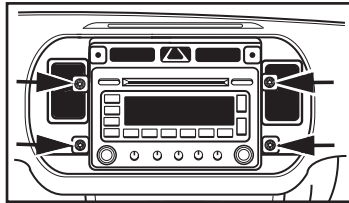

(Figura D)

Eos 2007 y mas

1. Desenganche y quite el panel de la moldura del radio. (Figura A)

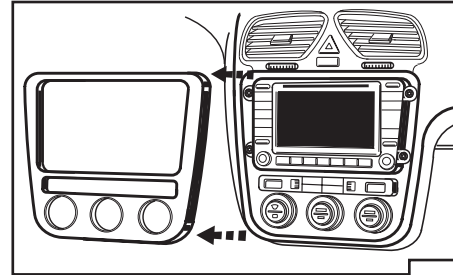

(Figura A)

2. Quite los (4) tornillos que sujetan el radio. Desconecte y quite el radio. (Figura B)

Continúe con el ensamble del kit

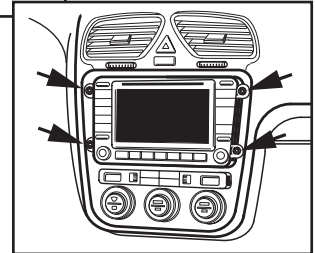

(Figura B)

Desmontaje del tablero

Beetle 2012 y mas

1. Desenganche y quite la pequeña moldura que rodea el radio. (Figura A)
2. Desenganche y quite la moldura más grande que rodea el radio, incluyendo las rejillas del aire acondicionado. (Figura B)
3. Quite los (4) tornillos Torx que sujetan el radio para quitarlo. (Figura C)

Continúe con el ensamble del kit

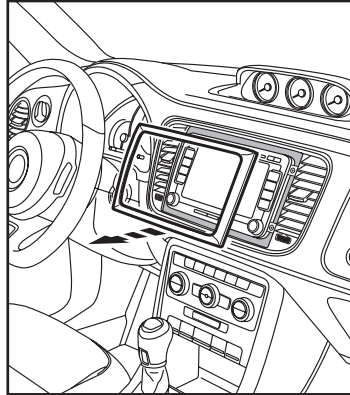

(Figura A)

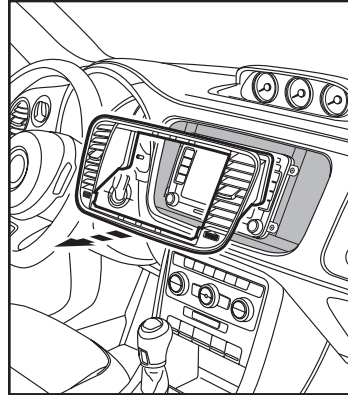

(Figura B)

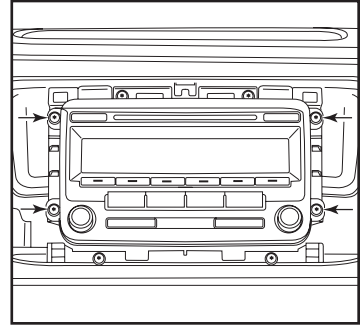

(Figura C)

Ensamble del kit

Provisión de radio doble DIN

1. Coloque a presión los soportes DDIN en el borde interior de la carcasa del radio. (Figura A)
2. Deslice el radio DDIN en el soporte/ensamble de carcasa del radio DDIN y sujete el radio al kit utilizando los tornillos suministrados con el radio. (Figura B)
3. Coloque a presión la placa de la moldura DDIN en la carcasa/conjunto del radio. (Figura B)
4. Ubique el arnés de cableado de fábrica en el tablero. Metra recomienda el uso de un adaptador adecuado de acoplamiento de Metra o de AXXESS. Vuelva a conectar la terminal negativa de la batería y pruebe la unidad para verificar que funcione correctamente.
5. Vuelva a armar el tablero al revés de como lo desarmó.

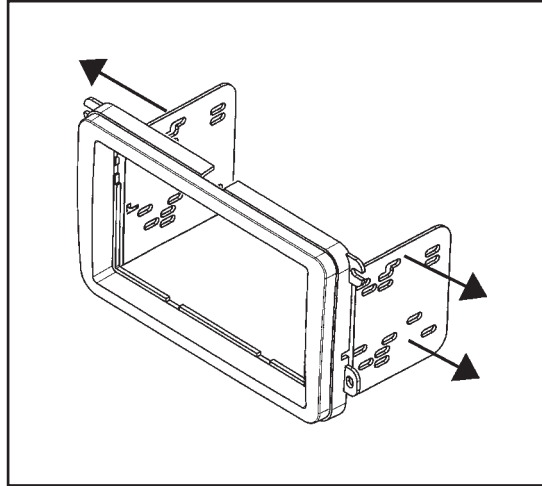

(Figura A)

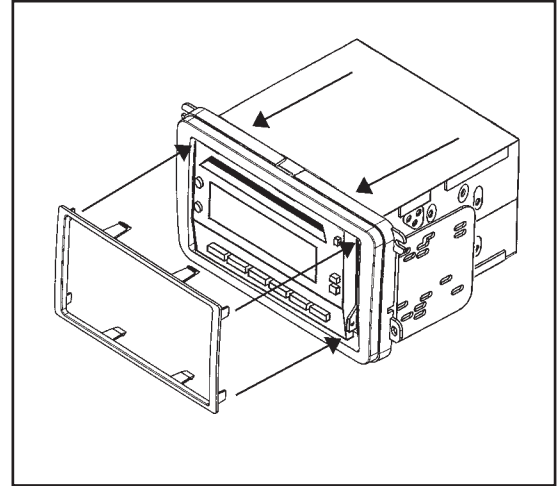

(Figura B)



INSTRUCCIONES DE INSTALACIÓN PARA LA PIEZA 95-9011



REV 12/17/2013 INST95-9011



EL CONOCIMIENTO ES PODER

Mejora sus habilidades de instalación y fabricación inscribiéndose en la escuela de dispositivos electrónicos móviles más reconocida y respetada de nuestra industria. Regístrese en www.installerinstitute.com o llame al 800-354-6782 para obtener más información y avance hacia un futuro mejor.



Metra recomienda técnicos con certificación del Programa de Certificación en Electrónica Móvil (Mobile Electronics Certification Program, MECP).