

Galaxy

DX 959_B

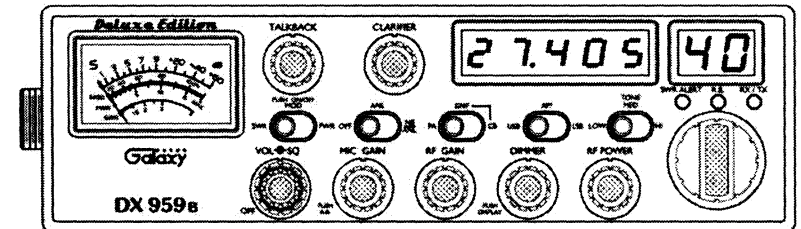

SOLID STATE CITIZENS BAND

AM/SSB MOBILE TRANSCEIVER

OWNER'S MANUAL

Printed in Vietnam
AT0949011C

TABLE OF CONTENTS

	PAGE
Specification	2
Installation	
Location	3
Mounting The Radio	3
Ignition Noise Interference	4
Antenna	4
Tuning The Antenna For Optimum SWR	5
External Speaker	6
Operation	
Control Functions	7
Front Panel	7
Rear Panel	10
Frequency List	11
Procedure to Receive and Transmit	12
Receiving SSB Signals	13
Alternate Microphone and Installation	15
Maintenance And Adjustment	18
A Few Rules That Should Be Obeyed	19
How Your CB Can Serve You	19
Use Channel 9 For Emergency Messages Only	20
Warranty	21

SPECIFICATIONS

GENERAL

Model	DX 959
Channels	40
Frequency Range	26.965 ~ 27.405 MHz
Emission	AM/USB/LSB
Frequency Control	Phase-Lock-loop (PLL) Synthesizer
Frequency Stability	0.001%
Temperature Range	-30°C to +50°C
Input Voltage	13.8 V DC
Antenna Impedance	50 Ohms
Speaker Impedance	8 Ohms
Size	7 7/8" (W) x 9 1/4" (D) x 2 1/8" (H)
Weight	5.5 lbs.

TRANSMITTER

RF Power Output	AM : 4W ; USB/LSB : 12W PEP
Frequency Response	300 to 2500 Hz
Frequency Tolerance	0.005%
Spurious Emission	Better Than -55 dB
Unwanted Sideband	Better Than -55 dB

RECEIVER

Sensitivity for 10 dB (S+N)/N	AM : 0.5 uV ; USB/LSB : 0.25 uV
Squelch Sensitivity	Less Than 0.5 uV
Audio Power Output	2W @ 10% Distortion
Image Rejection Ratio	-65 dB
AGC Figure of Merit	100 mV for 10dB Change in Audio Output
Audio Response	300 to 2500 Hz
Clarifier Range	± 1.0 KHz

(SPECIFICATIONS SUBJECT TO CHANGE WITHOUT NOTICE)

INSTALLATION LOCATION

Plan the location of the transceiver and microphone bracket before starting the installation. Select a location that is convenient for operation and does not interfere with the driver or passengers. In automobiles, the transceiver is usually mounted below the dash panel with the microphone bracket beside it.

MOUNTING THE RADIO

The transceiver is supplied with a universal mounting bracket. When mounting the bracket and radio to your car, make sure it is mechanically strong. Also, provide a good electrical grounding connection to the chassis of the vehicle. Proceed as follows to mount the transceiver:

1. After you have determined the most convenient location in your vehicle, hold the transceiver with mounting bracket in the exact location desired. If nothing will interfere with mounting it in the desired position, remove the mounting bolts. Before drilling the holes, make sure nothing will interfere with the installation of the mounting bolts.
2. Connect the antenna cable plug to the standard receptacle on the rear panel. Most transceiver antennas are terminated with a type PL-259 plug and mate with the ANT receptacle.
3. Connect the red DC power input wire (with the fuse) to +13.8V DC. This wire extends from the rear panel. In automobile installation, +13.8V DC is usually obtained from the accessory contact on the ignition switch. This prevents the set being left on accidentally when the driver leaves the car and also permits operating the unit without the engine running. Locate the accessory contact on most ignition switches by tracing the power wire from the AM broadcast receiver in the car.
4. Connect the black lead to -13.8V DC. This is usually the chassis of the car. Any convenient location with good electrical contact (remove paint) may be used.
5. Mount the microphone bracket on the right side of the transceiver or near the transceiver, using two screws supplied. When mounting in an automobile, place the bracket under the dash so that microphone is readily accessible.

IGNITION NOISE INTERFERENCE

Use of a mobile receiver at low signal levels is normally limited by the presence of electrical noise. The primary source of noise in automobile installation is from the generator and ignition system in the vehicle. Under most operating conditions, when signal level is adequate, the background noise does not present a serious problem. Also, when extremely low level signals are being received, the transceiver may be operated with vehicle engine turned off. The unit requires very little current and therefore will not significantly discharge the vehicle battery.

Even though the transceiver has ANL and NB controls, in some installations ignition interference may be high enough to make good communications impossible. The electrical noise may come from several sources. Many possibilities exist as variations between vehicles require different solutions to reduce the noise.

ANTENNA

A vertically polarized, quarter-wavelength whip antenna provides the most reliable operation and greatest range. Shorter, loaded-type whip antennas are more attractive, compact and adequate for applications where the maximum possible distance is not required. Also, loaded whips do not present the problems of height imposed by a full quarter-wavelength whip.

Mobile whip antennas utilize the metal body of the vehicle as a ground plane. When mounted at a corner of the vehicle they are slightly directional, in the direction of the body of the vehicle. For all practical purpose, however, the radiation pattern is nondirectional. The slight directional characteristic will be observed only at extreme distances. A standard antenna connector (type SO-239) is provided on the transceiver for easy connection to a standard PL-259 cable termination.

If the transceiver is not mounted on a metal surface, it is necessary to run a separate ground wire from the unit to good metal electrical ground in the vehicle. When installed in a boat, the transceiver will not operate at maximum efficiency without a ground plate, unless the vessel has a steel hull.

Before installing the transceiver in a boat, consult your dealer for information regarding an adequate grounding system and prevention of electrolysis between fittings in the hull and water.

TUNING THE ANTENNA FOR OPTIMUM S.W.R

Since there is such a wide variety of base and mobile antennas, this section will strictly concern itself to the various types of mobile adjustable antennas. Because the antenna length is directly related to the channel frequency, it must be tuned to resonate optimally on all channels of the transceiver. Channel 1 requires a longer antenna than Channel 40 because it is a lower frequency. Due to the various methods of adjusting antennas for proper S.W.R., we have chosen what we think is the optimum method:

A. Antenna with adjustable screws (set screws).

1. Start with the antenna extended and tighten the set screw lightly enough so that the antenna can be lightly tapped with your finger for easy adjustment.
2. Set your transceiver to Channel 20. Press the PTT (push-to-talk) switch, and tap the antenna (making it shorter). The S.W.R meter will show a lower reading each time the antenna is tapped. By continuing to shorten the antenna, you will notice the S.W.R reading will reach a low point and then start rising again. This means that you have passed the optimum point for Channel 20.

Extend the antenna a short distance and again follow the procedure above. When the lowest point has been reached, switch to Channel 1 and then to Channel 40 and compare S.W.R readings. They should be almost equal.

NOTE

THE PROPER SETTING IS ACHIEVED WHEN THE SWR IS 1.5 OR BELOW, AND WHEN IT HAS THE SAME READING FOR CHANNELS 1 AND 40.

B. Antennas which must be cut to proper length

1. Follow the same procedure as above, but adjust the length by cutting in 1/8" increments until a good match is obtained.

2. Be very careful not to cut too much at one time, as once it is cut, it can no longer be lengthened.
3. The whip is easily cut by filing a notch all the way around and breaking the piece off with pliers.

If you are having difficulties in adjusting your antenna, check the followings:

- a. All doors must be closed when adjusting the antenna
- b. Make sure the antenna base is grounded.
- c. Check your coaxial cable routing (it may be pinched when routed into the car)
- d. Try a different location in your car (keeping in mind the radiation pattern you wish.)
- e. Is the antenna perfectly vertical?
- f. Try a different location in your neighborhood. Stay away from large metal objects when adjusting (metal telephone or lamp post, fences, etc.)

NOTE

The transceiver will operate into an SWR of 2 to 1 indefinitely and sustain an SWR of 20 : 1 for a maximum of 5 minutes at rated operating conditions.

EXTERNAL SPEAKER

The external speaker jack (EXT. SP.) on the rear panel is used for remote receiver monitoring. The external speaker should have 8 ohms impedance and be able to handle at least 4 watts. When the external speaker is plugged in, the internal speaker is disconnected.

PUBLIC ADDRESS

To use the transceiver as a public address system, connect an external 8 ohms speaker (4 watts minimum) to the PA. SP. jack located on the rear panel. Direct speaker away from the microphone to prevent acoustic feedback. Physical separation or isolation of the microphone and speaker is important when operating the PA at high output levels.

OPERATION CONTROL FUNCTIONS FRONT PANEL

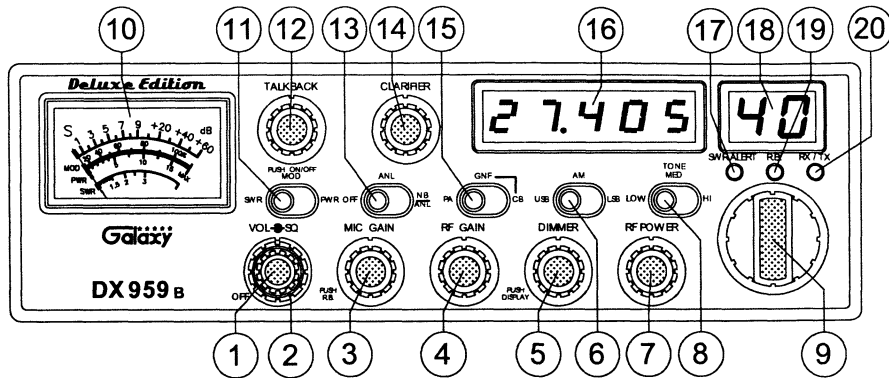

1. **ON/OFF VOLUME CONTROL:** Turn clockwise to apply power to the radio and to set the desired listening level.
2. **SQUELCH CONTROL:** This control is used to control or eliminate receiver background noise in the absence of an incoming signal. For maximum receiver sensitivity, it is desired that the control be adjusted only to the point where the receiver background noise is eliminated. Turn fully counter-clockwise, then slowly clockwise until the receiver noise disappears. Any signal to be received must now be slightly stronger than the average received noise. Further clockwise rotation will increase the threshold level which a signal must overcome in order to be heard. Only strong signals will be heard at maximum clockwise setting.
3. **MIC GAIN/R.B.:** Adjusts the microphone gain in the transmit and PA modes. This controls the gain to the extent that full talk power is available several inches away from the microphone. In the PUBLIC ADDRESS (PA) mode, the control functions as the volume control. Pushing this knob turns the Roger Beep on and off. When the Roger Beep is on, the radio transmits an audio tone at the end of your transmission. This indicates the end of your transmission so that people who are having trouble hearing you will know that you are done speaking. As a courtesy to others, use the Roger Beep only when necessary.

4. **RF GAIN CONTROL:** This control is used to reduce the gain of the receive amplifier under strong signal conditions.
5. **DIMMER CONTROL:** This knob controls the level of brightness for the meter lamp, the frequency display and the channel display. The back lighting of the faceplate lettering remains at maximum unless it is turned off. Also, pushing this knob turns the back lighting of the faceplate lettering, meter lamp, the frequency display and the channel display on and off.
6. **MODE SWITCH:** This control allows you to select one of the following operating modes: USB/AM/LSB.
7. **RF POWER CONTROL:** This control allows the user to adjust RF power output.
8. **TONE SWITCH HI/MED/LO:** This switch changes the tone quality. In LO position, bass is increased and in HI position, treble is increased.
9. **CHANNEL SELECTOR:** This control is used to select a desired transmit and receive channel.
10. **FRONT PANEL METER:** The Front Panel Meter allows the user to monitor signal strength, RF output power, SWR level and the AM Modulation level.
11. **SWR/MOD/PWR SWITCH:** This switch controls the function of the meter during the transmit mode. In the "SWR" position, the meter indicates the Standing Wave Ratio (SWR) of your antenna. There are no adjustments because the SWR circuit in this radio calibrates itself automatically. When the switch is in the "MOD" position, the green scale on the meter indicates your percentage of modulation. This operates in AM only, not in SSB. When this switch is in "PWR" position, the meter indicates your power output.
12. **TALKBACK CONTROL:** Pushing this knob turns the Talkback circuit on and off. Adjust this knob for desired volume of Talkback. This is used to monitor your own voice. For example, you could use this feature to compare different microphones.
13. **NB/ANL/OFF SWITCH:** In the "ANL" position, the Automatic Noise Limiter is activated. In the "NB/ANL" position, the Noise Blanker is also activated. The Noise Blanker is very effective in eliminating repetitive impulse noise such as ignition interference.

14. **CLARIFIER:** Allows tuning of the receive frequency above or below the channel frequency by up to 1.0 KHz. Although this control is intended primarily to tune in SSB signals, it may be used to optimize AM signals.

15. **PA/GNF/CB SWITCH:** In the "PA" position, your voice will come out of the speaker that you need to plug in to the "PA. SP." jack on the back of the radio. The radio does not operate when you are in the "PA" mode. The "CB" mode is normal operation of the radio. In the "GNF" mode, you are in CB operation but the Galaxy Noise Filter (GNF) is engaged. This is a special noise filter that de-emphasizes audio high frequency response in order to increase the signal-to-noise ratio of weak signals. While you will notice a dramatic reduction in the "rushing" sound when this filter is activated, it does not have much effect on the signal-to-noise ratio of strong signals.

16. **FREQUENCY COUNTER:** This display indicates the frequency of the selected channel.

17. **SWR ALERT LED:** This LED lights red when your SWR is higher than about 3:1. This is not an exact indicator of 3:1 SWR, but it is an indication that you should check your SWR reading.

18. **CHANNEL DISPLAY:** The channel display indicates the current selected channel.

19. **R.B. LED:** This LED lights blue when the Roger Beep is on.

20. **RX/TX LED:** This LED lights blue during receive and red during transmit.

REAR PANEL CONNECTOR

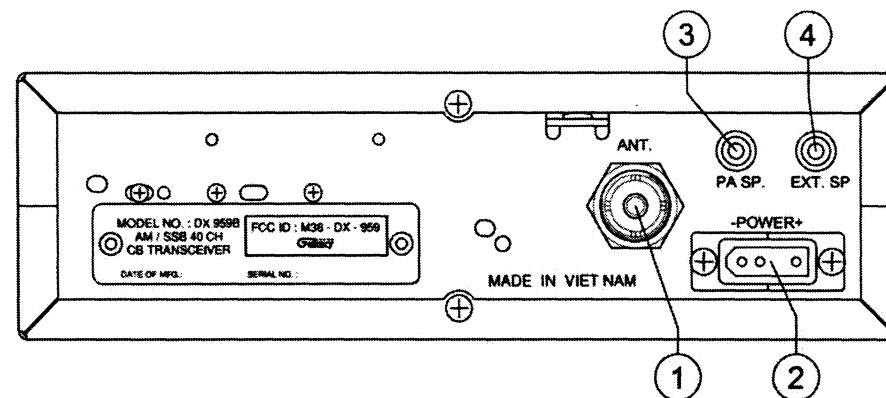

1. **ANTENNA:** This antenna jack accepts 50 ohms coaxial cable with a PL-259 type plug.

2. **POWER:** This accepts 13.8V DC power cable with built-in fuse. The power cord provided with the radio has a black and red wire. The black goes to negative and red goes to positive.

3. **PA. SP.:** This jack is for PA operation. Before operating, you must first connect a PA speaker (8 ohms, 4W) to this jack.

4. **EXT. SP:** This jack accepts 4 to 8 ohms, 5 watts external speaker. When the external speaker is connected to this jack, the built-in speaker will be disabled.

FREQUENCY RANGE

Channel	Channel Frequency	Channel	Channel Frequency
1	26.965 MHz	21	27.215 MHz
2	26.975 MHz	22	27.225 MHz
3	26.985 MHz	23	27.255 MHz
4	27.005 MHz	24	27.235 MHz
5	27.015 MHz	25	27.245 MHz
6	27.025 MHz	26	27.265 MHz
7	27.035 MHz	27	27.275 MHz
8	27.055 MHz	28	27.285 MHz
9	27.065 MHz	29	27.295 MHz
10	27.075 MHz	30	27.305 MHz
11	27.085 MHz	31	27.315 MHz
12	27.105 MHz	32	27.325 MHz
13	27.115 MHz	33	27.335 MHz
14	27.125 MHz	34	27.345 MHz
15	27.135 MHz	35	27.355 MHz
16	27.155 MHz	36	27.365 MHz
17	27.165 MHz	37	27.375 MHz
18	27.175 MHz	38	27.385 MHz
19	27.185 MHz	39	27.395 MHz
20	27.205 MHz	40	27.405 MHz

PROCEDURE TO RECEIVE AND TRANSMIT

A. MICROPHONE

The receiver and transmitter are controlled by the push-to-talk switch on the microphone. Press the switch and the transmitter is activated, release switch to receive. When transmitting, hold the microphone two inches from the mouth and speak clearly in a normal voice. This transceiver comes complete with a low impedance dynamic microphone.

B. PROCEDURE TO RECEIVE

1. Be sure that power source, microphone and antenna are connected to the proper connectors before going to the next step.
2. Turn unit on by running **VOL** knob clockwise on transceiver.
3. Set the **VOL** for a comfortable listening level.
4. Set the **MODE** switch to the desired mode.
5. Listen to the background noise from the speaker. Turn the **SQ** knob slowly clockwise until the noise just disappears. Leave the control at this setting. This **SQ** is now properly adjusted. The receiver will remain quiet until a signal is actually received. Do not advance the control too far or some of weaker signals will not be heard.
6. Set the **CHANNEL** selector switch to the desired channel.
7. Set the **RF GAIN** control fully clockwise for maximum receive gain.

C. RF POWER CONTROL

This feature allows for the adjustment of the RF power output continuously over the range of 1 to 4 watts in AM and 4 to 12 watts in USB or LSB.

D. PROCEDURE TO TRANSMIT

1. Select the desired channel of transmission
2. Set the **MIC GAIN** control fully clockwise.
3. If the channel is clear, depress the push-to-talk switch on the microphone and speak in a normal voice.

RECEIVING SSB SIGNALS

There are three types of signals presently used for communications in the Citizens Band : AM, USB, LSB. When the MODE switch on your unit is placed in the AM position, only standard double-sideband, full carrier signals will be detected. An SSB signal may be recognized while in the AM mode by its characteristic "Donald Duck" sound and the inability of the detector to produce an intelligible output. The USB and LSB modes will detect upper sideband and lower sideband respectively, and standard AM signals.

SSB reception differs from standard AM reception in that an SSB receiver does not require a carrier or opposite sideband to produce an intelligible signal. A single-sideband transmitted signal consists only of the upper or the lower sideband and no carrier is transmitted. The elimination of the carrier from the AM signal helps to eliminate the biggest cause of whistles and tones heard on channels which make even moderately strong AM signals unreadable. Also, SSB takes only half the space of an AM channel, therefore two SSB conversations will fit into each channel, expanding the 40 AM channels to 80 SSB channels. The reduction in channel space required also helps in the receiver because only *half* of the noise and interference can be received with 100% of the SSB signal.

An SSB signal may be received only when the listening receiver is functioning in the same mode. In other words, an upper sideband signal (USB) may be made intelligible *only* if the receiver is functioning in the USB position.

If a lower side band (LSB) signal is heard when the receiver is in the USB mode, no amount of tuning will make the signal intelligible. The reason for this may be understood if you consider that when the modulation is applied to the transmitter's microphone in the USB mode, the transmitter output frequency is increased whereas in the LSB mode the transmitter's output frequency is decreased.

The result in listening to the receiver is that when the MODE switch is in the proper position (either USB or LSB), a true reproduction of a single tone of modulation will result, and if the tone is increased in frequency (such as a low-pitched whistle or a high-pitched whistle) you will hear the increase in the output tone of the receiver. If the incorrect mode is selected, an increase in tone of a whistle applied to the transmitter will cause a decrease in the resultant tone from the receiver.

Thus when a voice is used in place of a whistle or tone, in the proper listening mode the voice will be received correctly whereas in the incorrect mode, the voice will be translated backwards and cannot be made intelligible by the CLARIFIER control. When listening to an AM transmission, a correct sideband is heard in either mode since both upper and lower sidebands are received.

Once the desired SSB mode has been selected, frequency adjustment may be necessary in order to make the incoming signal intelligible. The CLARIFIER control allows the operator to vary frequency above or below the exact frequency of the channel. If the sound of the incoming signal is high or low pitched, adjust the operation of the CLARIFIER.

Consider it as performing the same function as a phonograph speed control. When the speed is set too high, voices will be high-pitched and if set too low, voice will be low-pitched. Also, there is only one correct speed that will make a particular record produce the same sound that was recorded. If the record is played on a turntable that is rotated in the wrong direction (opposite sideband) no amount of speed control (CLARIFIER) will produce an intelligible sound.

An AM signal received while listening in one of the SSB modes will produce a steady tone (carrier) in addition to the intelligence, unless the SSB receiver is tuned to exactly the same frequency by the CLARIFIER control. For simplicity, it is recommended that the AM modes be used to listen to AM signals.

ALTERNATE MICROPHONES AND INSTALLATION

For best results, the user should select a low-impedance dynamic type microphone or a transistorized microphone. Transistorized type microphones have low output impedance characteristics. The microphones must be provided with a four-lead cable. The audio conductor and its shielded lead comprise two of the leads. The third lead is for transmit control and fourth is for receiving control.

The microphone should provide the functions shown in schematic below.

4 WIRE MIC CABLE

<u>Pin Number</u>	<u>Mic Cable Lead</u>
1	Audio Shield
2	Audio Lead
3	Transmit Control
4	Receive Control

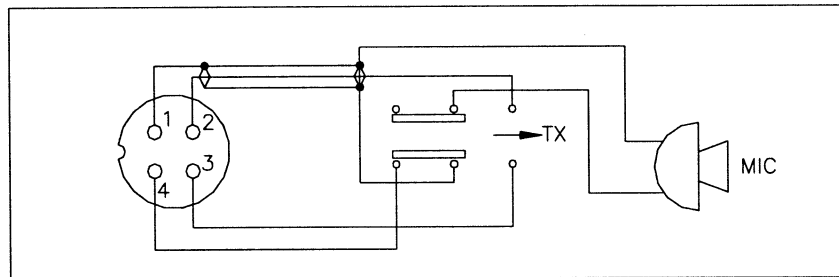

Fig. 1 Your transceiver microphone schematic.

If the microphone to be used is provided with pre-cut leads, they must be revised as follows.

1. Cut leads so that they extend 7/16" beyond the plastic insulating jacket of the microphone cable.
2. All leads should be cut to the same length. Strip the ends of each wire 1/8" and tin the exposed wire.

Before beginning the actual wiring, read carefully the circuit and wiring information provided with the microphone you select. Use the minimum heat required in soldering the connections. Keep the exposed wire lengths to a minimum to avoid shorting when the microphone plug is reassembled.

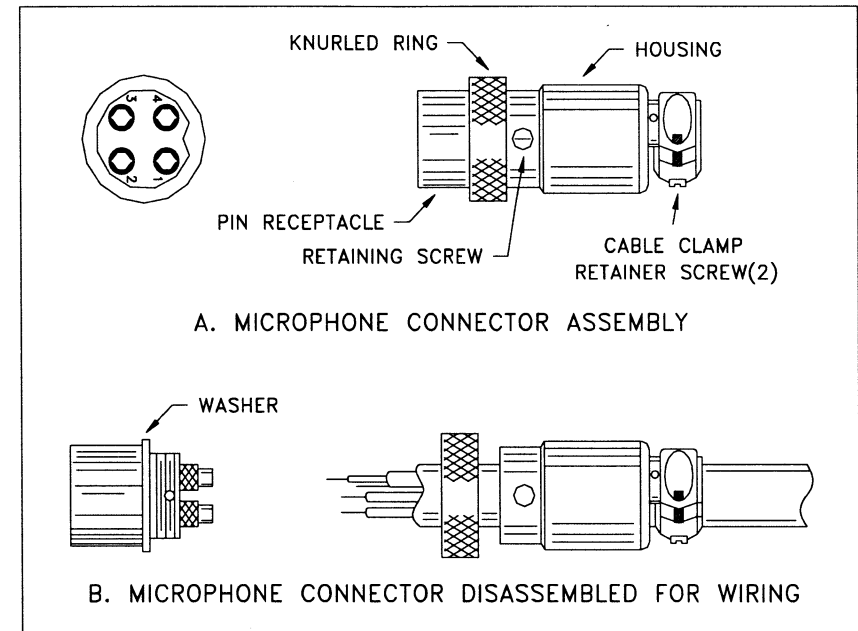

Fig. 2 Microphone plug wiring

To wire the microphone cable to the plug provided, proceed as follows:

1. Remove the retaining screw.
2. Unscrew the housing from the pin receptacle body.
3. Loosen the two cable clamp retainer screws.
4. Feed the microphone cable through the housing, knurled ring and washer as shown Figure 2.
5. The wires must now be soldered to the pins as indicated in the above wiring tables. If a vise or clamping tool is available it should be used to hold the pin receptacle body during the soldering operation, so that both hands are free to perform the soldering. If a vise or clamping tool is not available, the pin receptacle body can be held in a stationary position by inserting it into the

microphone jack on the front panel. The numbers of the microphone plug are shown in Fig. 3, as viewed from the back of the plug. Before soldering the wire to the pins, pre-tin the wire receptacle of each pin of the plug.

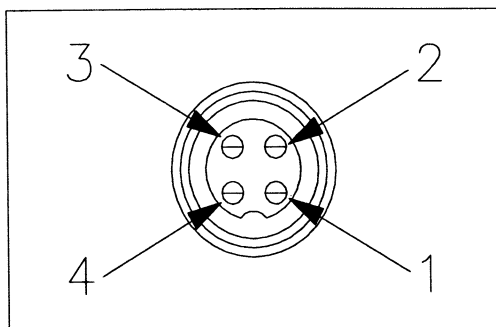

Figure 3 Microphone plug pin numbers viewed from rear of pin receptacle.

6. Be sure that the housing and the knurled ring of Figure 2 are pushed back onto the microphone cable before starting to solder. If the washer is not captive to the pin receptacle body, make sure that it is placed on the threaded portion of the pin receptacle body before soldering.
7. If the microphone jack is used to hold the pin receptacle during soldering operation, best results are obtained when the connections to pin 1 and 3 are made first and then the connections to pins 2 and 4. Use a minimum amount of soldering and be careful to prevent excessive solder accumulation on pins, which could cause a short between the pin and the microphone plug housing.
8. When all soldering connections to the pins of the microphone are completed, push the knurled ring and the housing forward and screw the housing onto the threaded portion of the pin receptacle body. Note the location of the screw clearance hole in the plug housing with respect to the threaded hole in the pin receptacle body.

When the housing is completely threaded into the pin receptacle body, a final fraction of a turn either clockwise or counterclockwise may be required to align the screw hole with the threaded hole in the pin receptacle body. When these are aligned, the retaining screw is then screwed into place to secure the housing to the pin receptacle body.

9. The two cable clamp retainer screws should now be tightened to secure the housing to the microphone cord. If the cutting directions have been carefully followed, the cable clamp should secure to the insulation jacket of the microphone cable.
10. Upon completion of the microphone plug wiring, connect and secure the microphone plug in the transceiver.

MAINTENANCE AND ADJUSTMENT

This transceiver is specifically designed for the environment encountered in mobile installations. The use of all solid state circuitry and its light weight result in high reliability. Should a failure occur, however, replace parts only with identical parts. Do not substitute.

NOTE

If the performance described in the OPERATION and MAINTENANCE AND ADJUSTMENT sections is not obtained, review the operating instructions to insure that proper procedures were followed.

FCC WARNING

All transmitter adjustments other than those provided on front panel by the manufacturer must be made by or under the supervision of the holder of an FCC – issued general radio telephone operator's license.

A FEW RULES THAT SHOULD BE OBEYED

1. You are not allowed to carry on a conversation with another station for more than five minutes at a time without taking a one-minute break, to give others a chance to use the channel.
2. You are not allowed to blast others off the air by over-powering them with illegally amplified transmitter power, or illegally high antennas.
3. You can't use the transceiver to promote illegal activities.
4. You are not allowed to use profanity.
5. You may not play music in your transceiver.
6. You may not use your transceiver to sell merchandised or professional service.

HOW YOUR CB CAN SERVE YOU

1. Warn of traffic tie ups ahead.
2. Provide weather and road information.
3. Provide help fast in event of emergency or breakdown.
4. Suggest good spots to eat and sleep.
5. Make long trips more interesting, and help keep you awake.
6. Provide direct contact with your office or home.
7. Make friends for you as you travel.
8. Provide "local information" to find your destination.
9. Help law enforcement officers by reporting drunk and reckless drivers.

USE CHANNEL 9 FOR EMERGENCY MESSAGES ONLY

The FCC gives the following examples of permitted and prohibited types of communications for use in an emergency. These are guidelines and are not intended to be all inclusive.

Permitted	Example Message
YES	"A tornado sighted six miles north of town."
NO	"This is observation post number 10. No tornado sighted."
YES	"I am out of gas on Interstate 95"
NO	"I am out of gas in my driveway"
YES	"There is a four-car collision at Exit 10 on the Beltway, send police and ambulance."
NO	"Traffic is moving smoothly on the Beltway"
YES	"Base to Unit 1, the Weather Bureau has just issued a thunder storm warning. Bring the sailboat into port."
NO	"Attention all motorists. The weather Bureau advises that the snow tomorrow will accumulate 4 to 6 inches.
YES	"There is a fire in the building on the corner of 6th and Main Streets."
NO	"This is Halloween patrol unit number 3. Everything is quiet here."

WARRANTY

This radio is covered by a two year
Limited parts and labor warranty

- "Limited" means that we will repair problems caused by factory defects or normal use at no charge.
- Before returning a radio to us for warranty service, please call our Service Department for a Repair Authorization Number (RAN). This RAN must be written below your return address on the outside of the shipping box. Boxes which arrive without a RAN will be refused, and the shipping company will return the unopened box to you. Be sure to have a pen and paper ready along with the serial number of your radio before calling. We will give you the RAN and our shipping address over the phone. The telephone number of the Service Department is (760)480-8800, and we suggest calling between 10.00 AM and 4.00 PM Pacific Time.
- Please include a note with a detailed description of the symptoms. This is important because it will help the technician who works on your radio to locate your problem. Intermittent problems are easily overlooked, so be sure to give as much detail as possible in your note. Also, please include your telephone number in case our technicians have any additional questions.
- Do not send your bracket, power cord or microphone unless we ask for these items during our telephone conversation.
- You are responsible for getting the radio safely to us. (We suggest using United Parcel Service.) You must pay to ship the radio to us, and we will pay to ship the radio back to you. Since we use UPS and they do not ship to Post Office boxes, please provide us with a street address for the return of your radio.
- We will repair and return your radio as soon as we can. We appreciate your choosing a Galaxy radio and we want you to be on the air as much as possible.

Be sure to visit our web site at:

www.GalaxyRadios.com