

# CleanSweep® CL-SES

source expander switch



## OWNER'S MANUAL

*Thank you for purchasing a JL Audio CleanSweep®  
Source Expander Switch for your automotive sound system.*

*This product has been designed and manufactured to exacting standards  
in order to ensure years of musical enjoyment in your vehicle.*

*For maximum performance and extended warranty  
coverage, we highly recommend that you have your CL-SES installed by  
an authorized JL Audio dealer. Your authorized dealer has the training,  
expertise and installation equipment to ensure optimum performance  
from this product without compromising your vehicle's functionality.  
Due to the complexity of modern vehicle systems we do not recommend  
self-installation unless you have extensive experience in  
automotive electrical systems.*

*If you have any questions regarding the instructions in this  
manual or any aspect of the product's operation, please contact your  
authorized JL Audio dealer for assistance. If you need further assistance,  
please call the JL Audio Technical Support Department  
at (954) 443-1100 during business hours.*



**SERIAL NUMBER**

In the event that your CleanSweep® CL-SES requires service or is ever stolen, you will need to have a record of the product's serial number. Please take the time to enter that number in the space provided below. The serial number can be found on the bottom panel of the unit and on the packaging.

**Serial Number:**

---

**PROTECT YOUR HEARING!**

We value you as a long-term customer. For that reason, we urge you to practice restraint in the operation of this product so as not to damage your hearing and that of others in your vehicle. Studies have shown that continuous exposure to high sound pressure levels can lead to permanent (irreparable) hearing loss. Automotive audio systems are capable of producing such high sound pressure levels. Please limit your continuous exposure to high volume levels.

While driving, operate your audio system in a manner that still allows you to hear necessary noises to operate your vehicle safely (horns, sirens, etc.).

## INSTALLATION APPLICATIONS

This product is designed for operation in vehicles with 12V, negative-ground electrical systems. Use of this product in vehicles with positive ground and/or voltages other than 12V may result in damage to the product and will void the warranty.

This product is not certified or approved for use in aircraft.

## PLANNING YOUR INSTALLATION

It is important that you take the time to read this manual and that you plan out your installation carefully.

### Safety Considerations:

Your CleanSweep® CL-SES needs to be installed in a dry environment and in a manner which does not interfere with your vehicle's safety equipment (air bags, seat belt systems, ABS brake systems, etc.). You should also take the time to securely mount the CleanSweep® CL-SES so that it does not come loose in the event of a collision or sudden acceleration / deceleration.

### Stupid Mistakes to Avoid:

- Check before drilling any holes in your vehicle to make sure that you will not be drilling through a gas tank, brake line, wiring harness or other vital vehicle system.
- Do not run system wiring outside or underneath the vehicle. This is an extremely dangerous practice that can result in severe damage to your vehicle and person.
- Protect all system wires from sharp metal edges and wear by carefully routing them, tying them down and using grommets and loom where appropriate.
- Do not mount this product in the engine compartment, under the vehicle, on the roof or in any other area that will expose it to the elements.

## PRODUCT OVERVIEW

The CL-SES is a high-quality audio source switch which allows you to expand any single stereo auxiliary input to accept up to three stereo source units. The CL-SES can be used to expand the auxiliary input capabilities of an OEM interface processor or any head unit that provides an auxiliary line-level input, including many OEM head units.

The CL-SES utilizes differential-balanced inputs to provide superior noise immunity and ensure compatibility with a wide range of source units. Advanced, solid-state CMOS switching ensures clean, distortion-free audio with no mechanical contacts to wear or corrode.

Switching between source units can be accomplished via automatic signal sensing **OR** manually operated switch (included):

**Automatic Mode** uses signal-sensing to switch between source units. You determine which source units have priority over others and select between them simply by turning them on or off.

**Manual Mode** uses the included remote push-button to switch between source units. When you are finished with a particular source, press the switch to go to the next source. Active inputs switch in sequence from "A" to "B" to "C" and then back to "A", etc.

Level-trim controls are provided for each input to aid in achieving equal sound levels between sources.

Each input has a corresponding LED indicator (located on the top panel of the CL-SES) to indicate when it is the active input.

## POWER CONNECTIONS

Before installing the CL-SES, disconnect the negative (ground) wire from the vehicle's battery. This will prevent accidental damage to the system, the vehicle and your body during installation.

The CL-SES has a three-wire inline jack located next to the **“Manual Override Connector”**. This jack accepts the following connections:

- “+12 V”: Constant +12V
- “GND”: Chassis Ground
- “IGN”: Switched +12V

Since the CL-SES does not draw very much current during operation, 18 AWG - 16 AWG wire is ample for making all of these connections. Use good-quality crimp connectors (or solder and heat shrink tubing) to join the harness leads to any extended wires. Any wires that run through metal barriers (such as firewalls), must be protected with a high quality rubber grommet to prevent damage to the insulation of the wire. Failure to do so may result in a dangerous short circuit.

The **“IGN”** connection is designed to do the following: the CL-SES will only turn on when +12V is present at this connection. Conversely, the CL-SES will shut off as soon as +12V is removed from this connection. This prevents the CL-SES from remaining on. Connect the **“IGN”** wire to a 12-volt circuit in the vehicle that is only energized with the key in the **“Accessory”** (ACC) or **“Ignition”** (IGN) positions.

Ideally, the **“+12V”** (constant) and **“GND”** (chassis ground) connections should be run to the same distribution points that the amplifiers use for their power and ground connections. This minimizes the possibility of noise in the system. A constant 12-volt connection is necessary for the CL-SES to **“remember”** the last selected source when used in the **“manual”** switching mode.

## FUSE REQUIREMENTS

The **“+12V”** constant wire on the CL-SES power harness has an inline 1 amp, fast blow AGC (small glass-bodied) fuse for protection of the unit. Do not remove this fuse or replace it with a different value of fuse.

## OUTPUT CONNECTIONS

Two RCA-type jacks provide two-channels of analog audio output to feed the auxiliary input of the head unit or OEM Interface Processor. These are located next to the **“Manual Override Connector”** and are clearly labeled for each channel.

# OUTPUT AND POWER CONNECTION PANEL

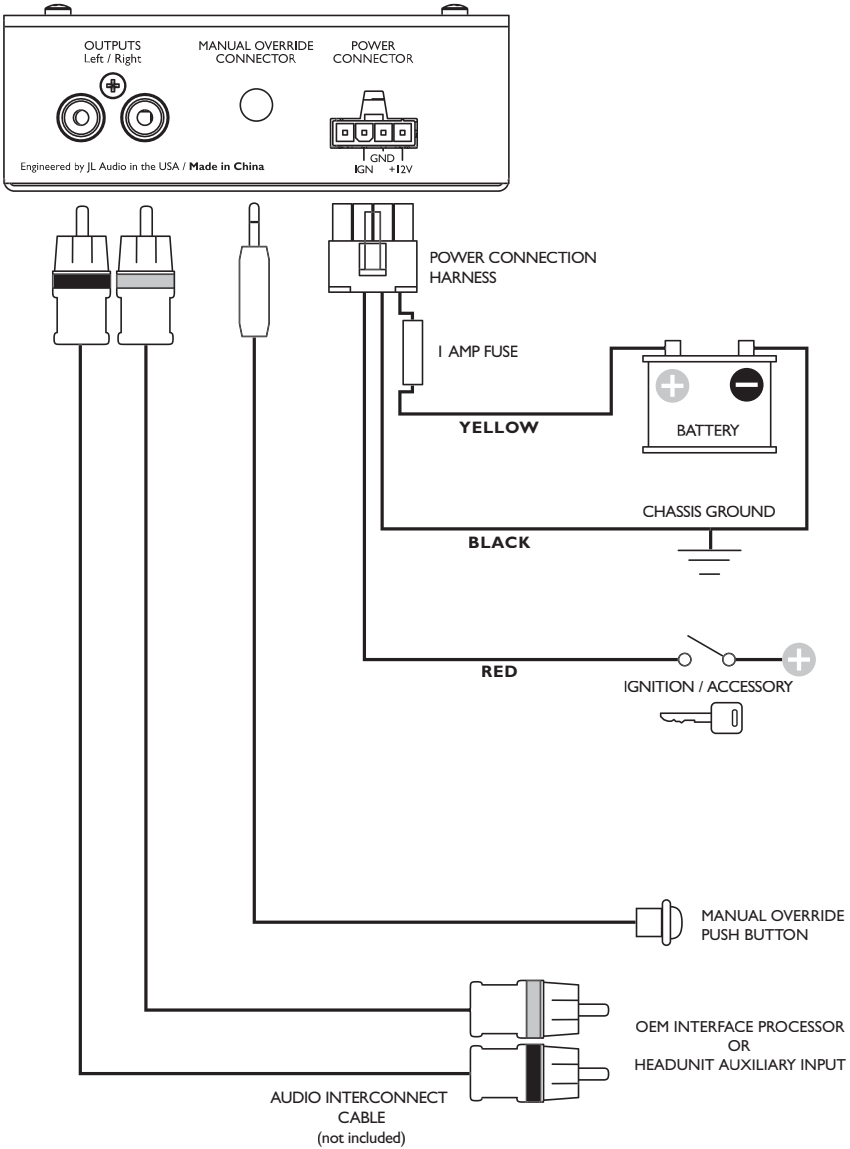

## INPUT CONNECTIONS

The CL-SES accepts up to three separate stereo input sources via six RCA-type jacks located on one end of the main chassis. To connect an auxiliary source, you will need standard RCA-type audio interconnect cables (not included). Depending on the source unit, you may also need additional cable adaptors.

The input architecture is set up in a differential-balanced configuration, making these inputs compatible with virtually any analog audio signal.

If you will be powering the AUX sources from the vehicle, it is a good practice to make the AUX source's power and ground connections at the same point as the rest of the system. This minimizes the possibility of ground loops and noise in the system.

### **! IMPORTANT**

**If your AUX source unit gives you the option of a fixed line-level output or a variable output (controlled by its volume control), use the fixed line-level output for best fidelity.**

## LEVEL TRIM CONTROLS

Each AUX INPUT features a dedicated "Level Trim" rotary control located on the top of the CL-SES. Use these level-trim controls to establish equivalent average audio levels between the source units.

## AUTOMATIC SWITCHING MODE

When in Automatic Mode, the CL-SES uses signal sensing and a priority system to determine which source will play. To operate the CL-SES in automatic switching mode, do NOT connect the push-button selector switch to the "Manual Override Connector".

The input pairs are prioritized as follows:

- "AUX INPUT A" - First Priority
- "AUX INPUT B" - Second Priority
- "AUX INPUT C" - Third Priority

If more than one source is playing, the CL-SES will choose the source connected to the highest priority input that is receiving signal. Switching from a lower priority source to a higher priority source is immediate. When switching from a higher priority source to a lower priority source the CL-SES will delay switching by 10-12 seconds. This prevents undesired switching during quiet passages in a track and/or silence between tracks.

If a track has an unusually long quiet passage or a very long fade in or fade out, the CL-SES may switch unexpectedly.

If there are no active sources, the CL-SES will rest at "AUX INPUT C" until a source is activated and you may hear a low-level hissing sound if the head unit's or OEM Interface Processor's auxiliary input is selected.

In the example outlined in the diagram on the opposing page, the satellite radio tuner ("AUX INPUT C") would only be audible when the portable music player ("AUX INPUT B") and DVD player ("AUX INPUT A") are paused or turned off. Turning on either the portable music player or the DVD player would override the satellite radio tuner's audio. The DVD player would override the portable music player's audio.

When planning the installation, decide which source units you wish to assign higher priority to and connect them to the appropriate inputs of the CL-SES using good-quality audio interconnect cables.

## MANUAL MODE

To operate the CL-SES in manual mode, connect the included push-button switch to the "Manual Override Connector". The push button selector switch should be installed within easy reach of the driver, on the center console or dashboard of the vehicle.

To switch sources in manual mode, simply press the switch to go to the next source. Active inputs switch in sequence from "A" to "B" to "C" and then back to "A", etc.

In manual mode, the CL-SES will "remember" the last AUX INPUT source selected when the vehicle is turned off and return to that source when the vehicle is restarted.

## INPUT CONNECTION PANEL

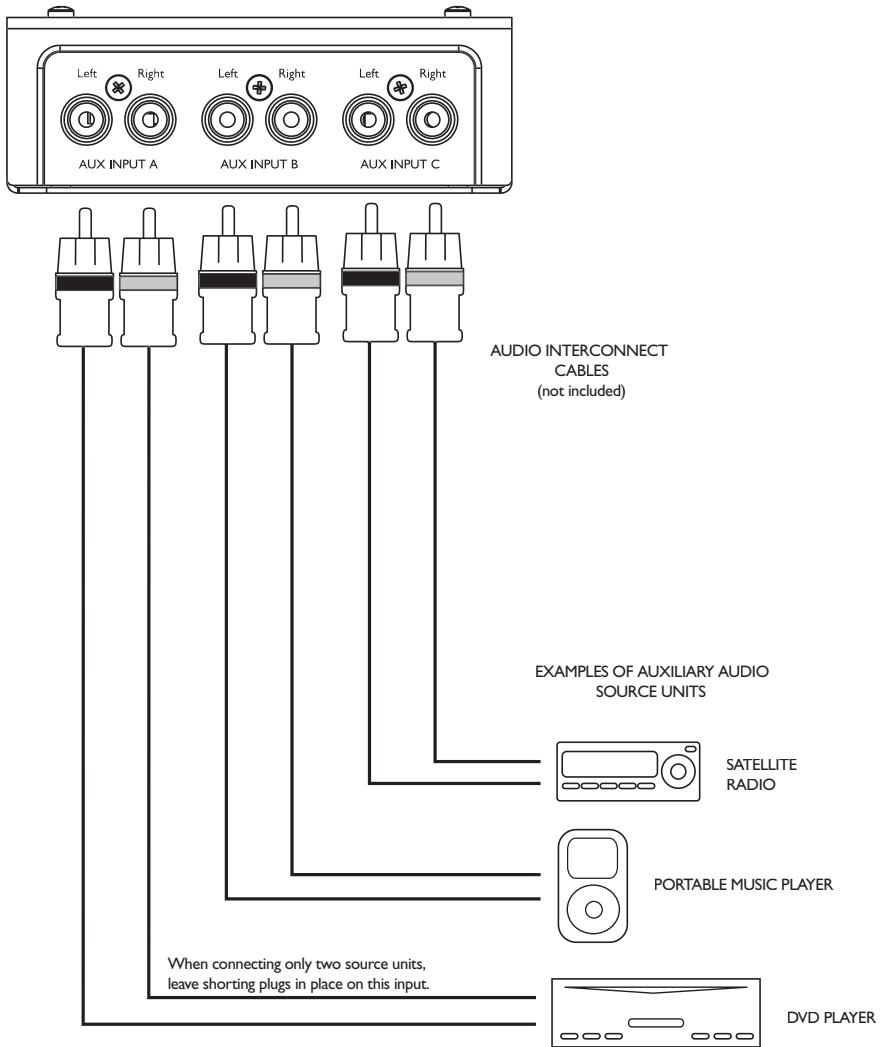

### **! IMPORTANT**

If you will be connecting only two sources to your CL-SES, only use auxiliary inputs “B” & “C” to make your connections. Leave the RCA shorting-plugs that are shipped with your unit in “AUX INPUT A.” Use of these shorting plugs helps prevent noise and false-switching problems.

## LEVEL TRIM CONTROLS

Each AUX INPUT features a dedicated “Level Trim” rotary control located on the top of the CL-SES. Use these level-trim controls to establish equivalent average audio levels between the auxiliary source units.

These can also be adjusted to match the level of the CL-SES output to the head unit’s aux input so as to achieve equivalent audio level between the head unit’s sources and the auxiliary sources.

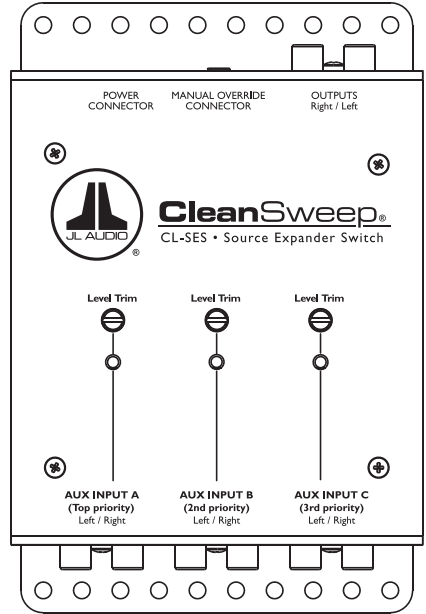



## PARTS LIST

- (1) CleanSweep® CL-SES Source Expander Switch
- (1) Manual Source Selector Switch and hardware
- (1) Power connection harness with inline fuse holder, 1A AGC fuse and plug
- (2) RCA shorting-plugs (for use with AUX INPUT A only)

## SPECIFICATIONS

### CleanSweep® CL-SES

### Signal Source Expander Switch

#### Electrical Specifications:

Power Supply Type: PWM Switching Supply - Regulated

Operating Voltage: 9 - 16V DC

Standby Mode Current Draw: < 2 mA

Operating Current Draw: 0.21 A at 13.8V

Recommended Fuse Value: 1 A (Fast Blow)

Recommended Fuse Type: AGC

#### Input Section:

No. of Input Channels: Three Stereo Pairs

Input Type: RCA-type jacks, differential-balanced inputs

Maximum Input Voltage: 5.0 Vrms

Input Level Setting: Manual, with individual level trim controls

Input Impedance: 10 kΩ

#### Output Section:

No. of Output Channels: One Stereo Pair

Output Type: Unbalanced, via RCA-type jacks

Maximum Output Voltage: 5 Vrms (per output)

Output Impedance: 470 ohms

Signal to Noise Ratio: <110 dB (with A-Weighted filter at 5.0 Vrms. 20Hz-20kHz)

THD + Noise: < 0.01% at 5.0 Vrms (20Hz - 20 kHz)

#### Dimensions(LxWxH):

5.02 in. x 4.36 in. x 1.52 in. (128 mm x 111 mm x 39 mm)

Due to ongoing product development, all specifications are subject to change without notice.

## TROUBLE SHOOTING

### **“My CL-SES doesn’t turn on.”**

**Check** to make sure there is +12V at the “+12V” and “IGN” power connections of the CL-SES. Also check the ground connection.

**Check** the fuse, not just visually, but with a continuity meter. It is possible for a fuse to have poor internal connections that cannot be found by visual inspection. It is best to take the fuse out of the holder for testing. If no problem is found with the fuse, inspect the fuse-holder.

### **“My system has alternator whine when using the CL-SES.”**

**Check** that the CL-SES is grounded to the same point as the amplifier(s) in the system and that all its connected sources deriving power from the vehicle are also grounded with the amplifier(s).

**Check** the input connectors and cables to ensure that they all are making good contact with the input jacks on the CL-SES.

### **“On some songs, my CL-SES switches when it is not supposed to.”**

**Please** review the functional description of the automatic mode on page 6 of this manual. This may occur with songs that contain very quiet passages or that fade in or out very gradually. If this behavior is not acceptable, consider using the unit in “manual mode” with the included switch.

### **“One source unit is much louder than the others.”**

**Please** use the level trim controls on that input to attenuate the level of the source that is too loud to match the other source units.



## **LIMITED WARRANTY - ELECTRONICS (USA)**

JL AUDIO warrants this product to be free of defects in materials and workmanship for a period of ninety (90) days from the original date of purchase. The warranty term is extended to two (2) years if installation is performed or approved by an authorized JL AUDIO dealer (proof of installation or approval required on purchase receipt).

This warranty is not transferrable and applies only to the original purchaser from an authorized JL AUDIO dealer. Should service be necessary under this warranty for any reason due to manufacturing defect or malfunction, JL AUDIO will (at its discretion), repair or replace the defective product with new or remanufactured product at no charge. Damage caused by the following is not covered under warranty: accident, misuse, abuse, product modification or neglect, failure to follow installation instructions, unauthorized repair attempts, misrepresentations by the seller. This warranty does not cover incidental or consequential damages and does not cover the cost of removing or reinstalling the unit(s). Cosmetic damage due to accident or normal wear and tear is not covered under warranty.

### **Warranty is void if the product's serial number has been removed or defaced.**

Any applicable implied warranties are limited in duration to the period of the express warranty as provided herein beginning with the date of the original purchase at retail, and no warranties, whether express or implied, shall apply to this product thereafter. Some states do not allow limitations on implied warranties, therefore these exclusions may not apply to you. This warranty gives you specific legal rights, and you may also have other rights which vary from state to state.

### **If you need service on your JL AUDIO product:**

All warranty returns should be sent to JL AUDIO's Electronics Service Facility freight-prepaid through an authorized JL AUDIO dealer and must be accompanied by proof of purchase (a copy of the original sales receipt). Direct returns from consumers or non-authorized dealers will be refused unless specifically authorized by JL AUDIO with a valid return authorization number.

Warranty expiration on products returned without proof of purchase will be determined from the manufacturing date code. Coverage may be invalidated as this date is previous to purchase date. Non-defective items received will be returned freight-collect. Customer is responsible for shipping charges and insurance in sending the product to JL AUDIO. Freight damage on returns is not covered under warranty.

### **For Service Information in the U.S.A. please call:**

**JL Audio customer service: (954) 443-1100**

**during normal business hours (9:00 AM - 5:30 PM Eastern Time)**

**JL Audio, Inc**

10369 North Commerce Pkwy.

Miramar, FL 33025

(do not send product for repair to this address)

### **International Warranties:**

Products purchased outside the United States of America are covered only by that country's distributor and not by JL Audio, Inc.